

Loven II

Loven Deck Mounted 3H B&S
Mixer

FFAS1M00-601500BF0



FEATURES

- A grade brass, strong and durable
- High quality ceramic valve for longer usage
- Ceramic cartridge tested = 500,000 times
- Neoperl aerator
- 3-functions hand shower
- With shower hose & shower hanger
- With normal packaging
- Flow rate @ 0.1MPa: 10.3 L/min for spout
- Flow rate @ 0.1MPa: 4.8L/min for shower

DIMENSIONAL DRAWING

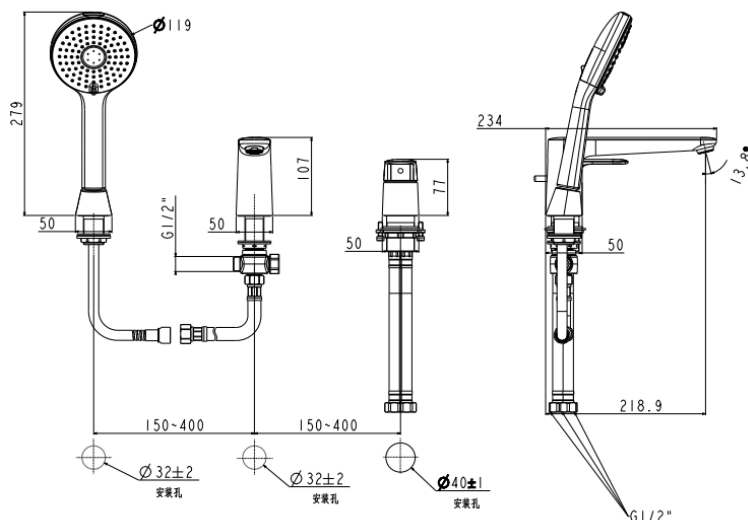

SPECIFICATIONS

- DM 3-hole bath & shower mixer faucet
- 3-hole installation: Single handle (cold & hot)
- Spout reach: 218.9 mm

FINISHES AVAILABILITY

Chrome (- CP)

AWARDS WON

- N/A

SHIPPING WEIGHT

- Product gross weight: 4.165kg /set
- Product net weight: 4.02kg /set

STANDARDS CRITERIA

- GB 18145-2014