

FFAS1304-101GLOBTO

Acacia Evolution

Acacia E In-Wall Vessel Mixer

#### STYLE SEGMENT

- Modern

#### KEY SPECIFICATIONS

- Product Description: In-Wall Basin Mixer
- Colour: Cool Sunrise
- Faucet Type: Mixer
- No. of Faucet Holes Required: 1
- Flow Rate: 4.62
- Is Drain Included: Yes
- Connection Size (inches): G1/2

#### SHIPPING WEIGHT

- Net Weight: Contact us for more information
- Gross Weight: Contact us for more information

#### KEY TECHNOLOGIES AND FEATURES

##### HYGIENE

- Complies with American Standard Quality Standards

##### COMFORT

- Comfort Angle

##### CONVENIENCE

- Complies with American Standard Quality Standards

##### DURABILITY

- Durashine

##### SUSTAINABILITY

- Water-Saving
- EcoStart
- ClickMove

##### SAFETY

- Complies with American Standard Quality Standards

##### OTHERS

- NIL

#### STANDARDS AND CERTIFICATIONS

- GB 18145-2014



FFAS1304-101GLOBTO

Acacia Evolution

Acacia E In-Wall Vessel Mixer

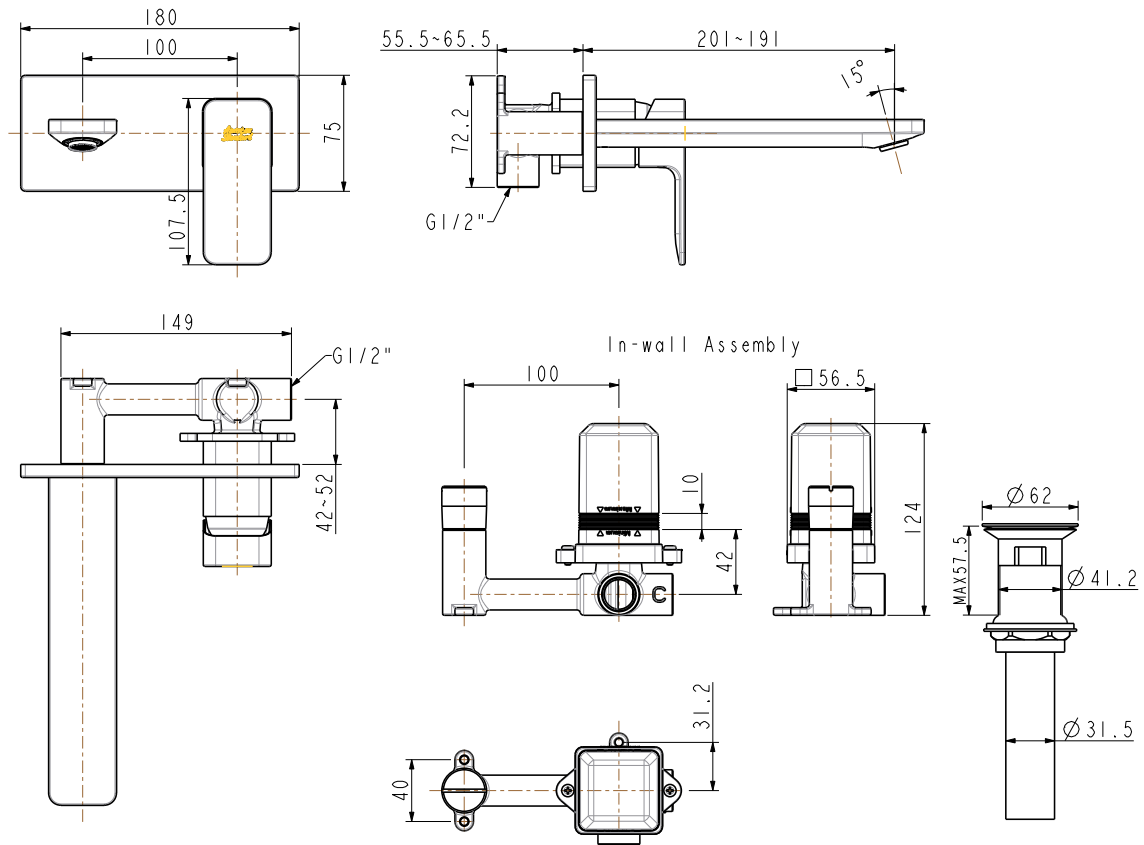

FFAS1304-101GLOBTO

Acacia Evolution

Acacia E In-Wall Vessel Mixer

<b>Product</b>	Description	In-Wall Basin Mixer
	Weight (kg)	4.62
	Finish	PVD
	Flow Rate	4.62
	Mounting Location	Wall Mount
<b>Material &amp; Color</b>	Material	Brass
	Color	Cool Sunrise
<b>Faucet</b>	Type	Mixer
	No. of Holes Required	1
<b>Connection</b>	Size (mm)	21
	Size (inches)	G1/2
<b>Handle</b>	Material	Zinc Die Cast
	Type	Lever
	No. of Handles	1
<b>Components</b>	Drain Included	Yes
	Included	Click Drain
	Excluded	N/A
<b>Spout</b>	Hose Thread in Spout	No
	Dimensions (mm)	Spout Reach 191-201
	Type	Ceramic
<b>Valve</b>	Type	Standard