

## Test / Usage

### 1 Test

- \* Push lever down to 'OFF' position. Open water supply valve to check all connections for leakage(s).
- \* Lift lever up to 'ON' position. Check that water is flowing from spout.

### 2 Usage

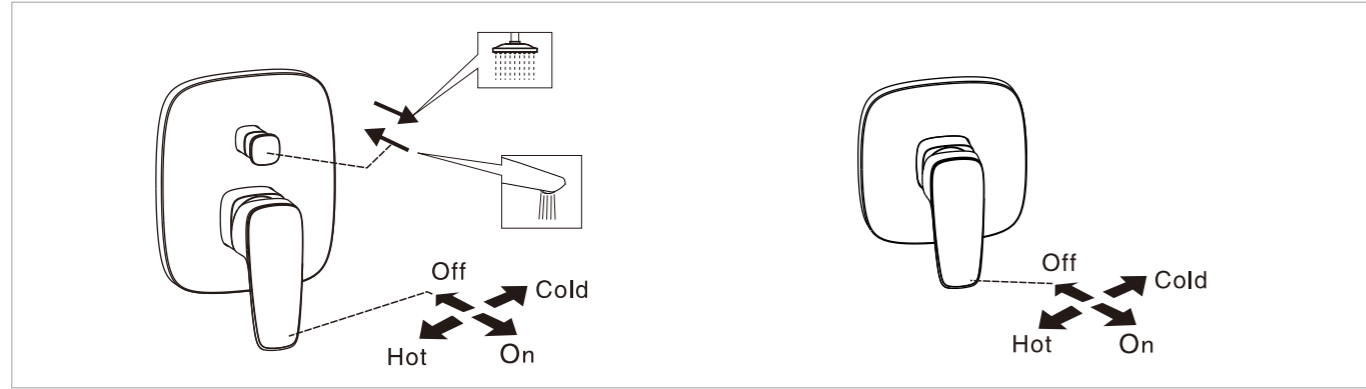

## Trouble Shooting Guide

Issue	Component	Checkpoint	Corrective Action
Poor flow rate	Shower	Check if shower is clogged	Remove all impurities
	Water supply valve	Check lever position	Lift lever to maximise water volume
Leakage	Cartridge	Check if cartridge is loosened	Fasten or replace cartridge
	Connection joints	Check the connection	Reassemble connecting part
Abnormal Temperature	Water supply valve	Check lever position	Lift lever to maximise water volume
	Water supply pipeline	Check if supply pipes have been correctly connected	Connect the hot and cold water pipe correctly

## Care & Maintenance

- \* Clogged cartridges due to poor water quality can affect product performance.
- \* Follow steps below to maintain optimal product performance.
- \* Note: please turn off water supply before maintenance process.

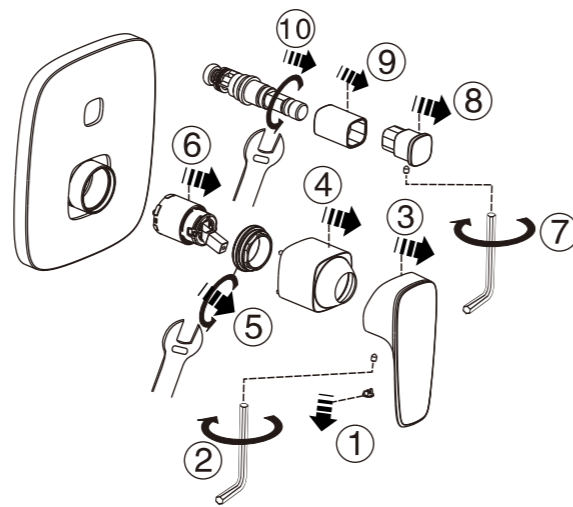

**Attention:**  
Please leave manual with customer post installation.

## Signature

FFAS1721-609XXXBT0  
Signature concealed bath & shower mixer

FFAS1722-709XXXBT0  
Signature concealed shower mixer

XXX=AL0 / A00 / DA0 / GL0 / 440

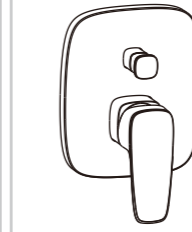

FFAS1721-609XXXBT0

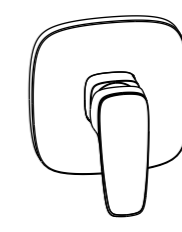

FFAS1722-709XXXBT0

American Standard

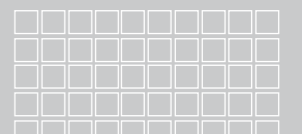

Installation &  
Operation Instructions

Thank you for selecting American Standard the benchmark of fine quality for over 100 years. To ensure that your installation proceeds smoothly, please read these instructions carefully before you begin.

- \* American Standard continually improves our product design and performance and reserves the right to modify the dimension and specification of our product accordingly without any prior notification.
- \* Actual dimensions and specifications may vary, refer to physical product for exact dimensions and specification.

## Pre-Installation Checks

- \* Remove all impurities from pipes before installation to avoid clogging. Connect faucet pipes correctly. Ensure that the cold water hose is connected to the right side and the hot water hose to the left.
- \* Check installation distances shown in the dimension diagram to ensure correct installation.
- \* Warning: Avoid lifting/ holding product lever only during installation. Instead, hold product spout/ main body.

### Conditions for use

- \* Water pressure condition: 0.05~0.75MPa (Recommended water pressure condition: 0.1~0.5MPa)
- \* Ambient temperature: 1~55°C
- \* Water temperature: 4°C ~ 90°C (Recommended hot water temperature 50~60°C)
- \* Steam should not be used with product.
- \* Note: Ensure water source is clean. Poor water quality can cause cartridge and internal components to clog, resulting in poor volume control and/ or product failure.

## Recommended Tools and Materials



Wrench



Level



Screwdriver



Tape Measure



Pencil



Teflon Tape

## Dimension

FFAS1721-609XXXBT0

Unit: mm

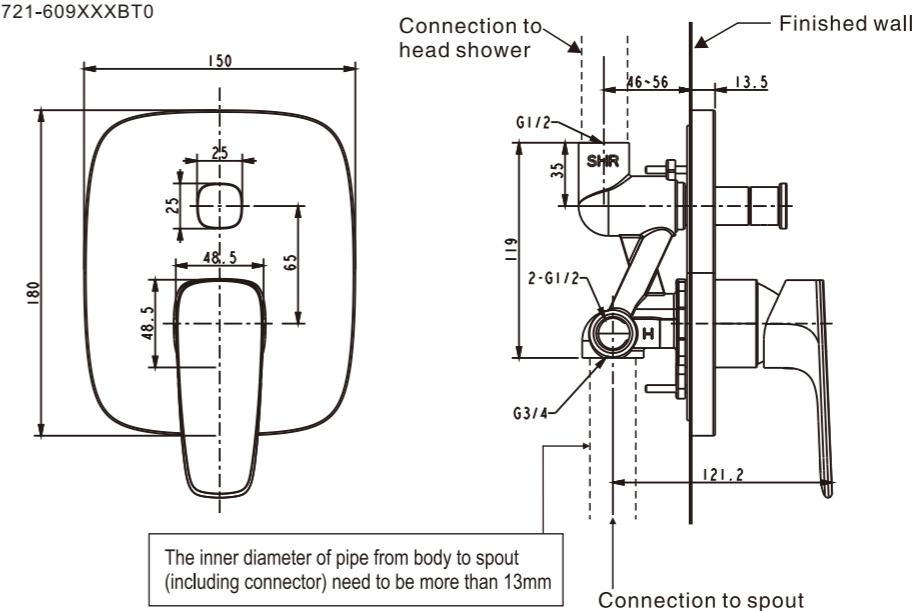

## Dimension

Unit: mm

FFAS1722-709XXXBT0

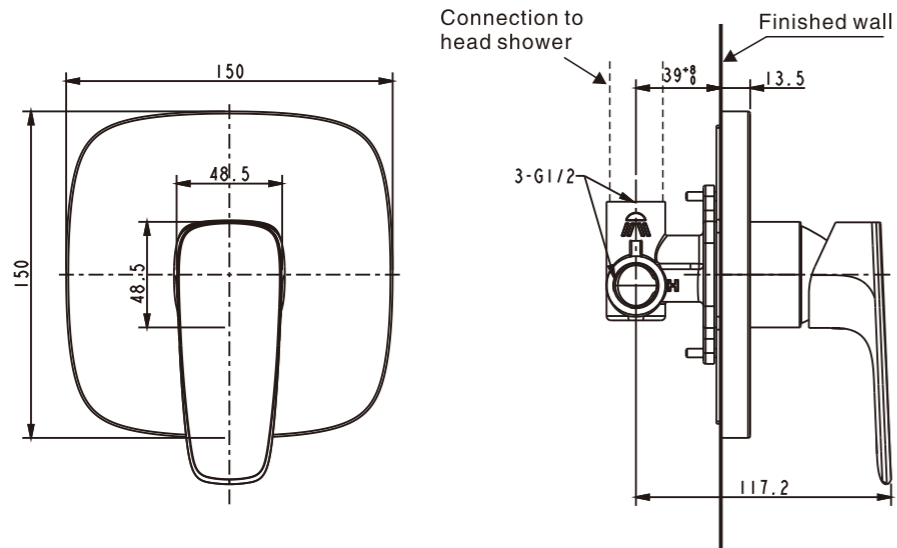

## Parts List

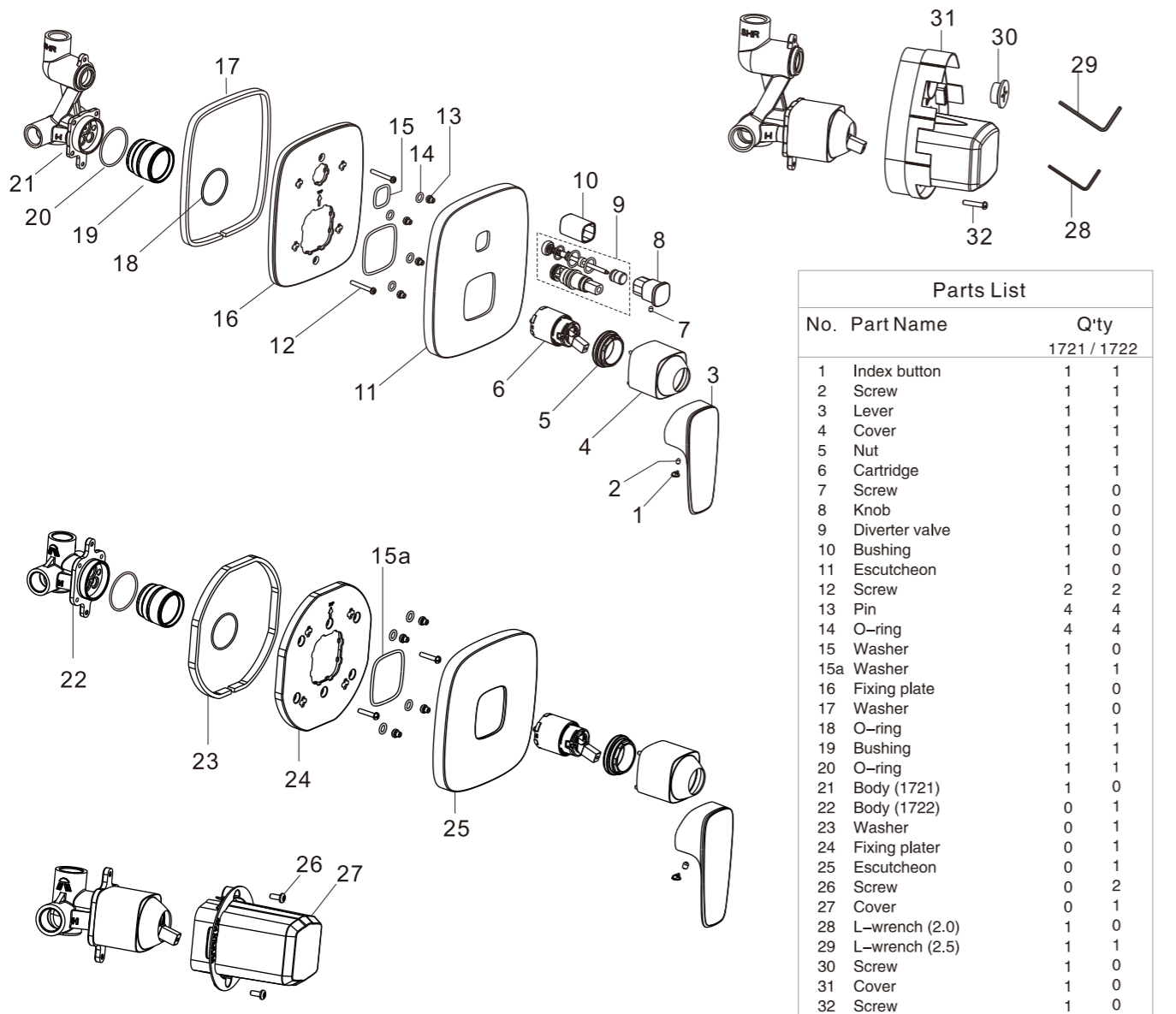

## Installation

### 1 Body Installation

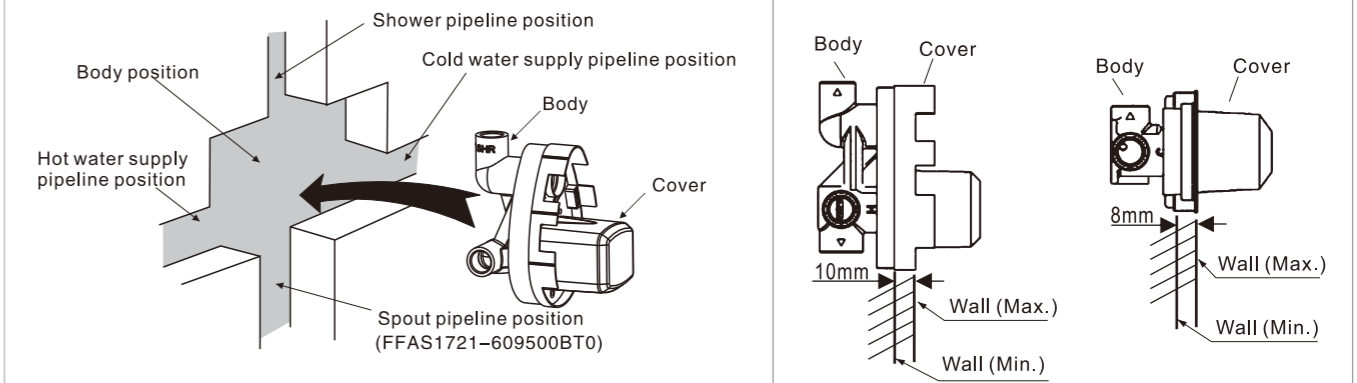

- \* Consult the dimension drawing and lay the pipes.
- \* Digging pit slot.
- \* Wash and clean the water supply pipeline.

- \* Finishing wall should be between the minimum and the maximum.

### 2 Finishing the Wall

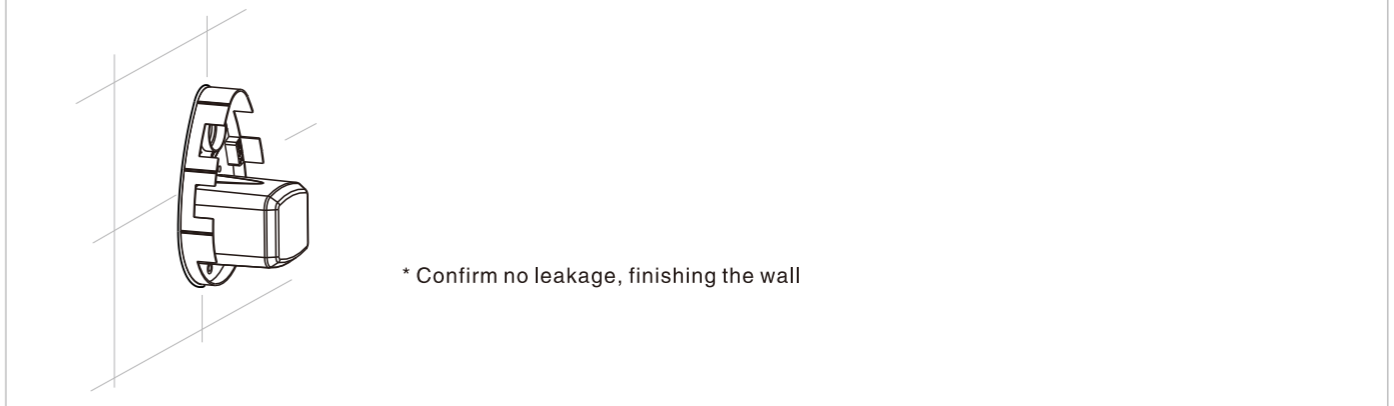

### 3 Escutcheon & Lever Installation

