

# Signature

# American Standard

Exposed Bath & Shower mixer with integrated Rainshower kit  
FFAS1772-701DA0BT0



## FEATURES

- A grade brass, strong and durable
- Grohe High quality ceramic valve for longer usage
- Ceramic cartridge tested = 500,000 times
- With Ceramic 3-way diverter cartridge
- With Rainshower kit
- With 3F hand shower
- With Easy-slide shower holder
- With 1.5m Twist-free shower hose
- With normal packaging
- Flow rate @ 0.1MPa: 7.5 L/min for Spout
- Flow rate @ 0.1MPa: 5.1 L/min for shower head
- Flow rate @ 0.1MPa: 4.6 L/min for hand shower

## DIMENSIONAL DRAWING

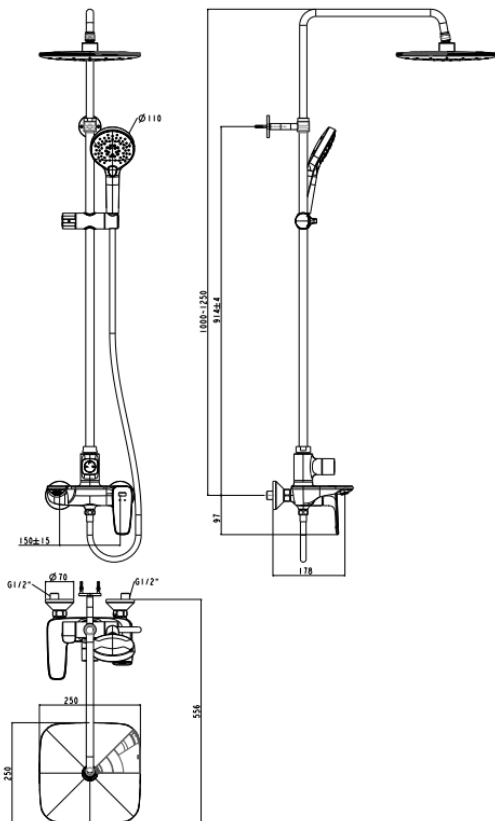

## SPECIFICATIONS

- Exposed Bath & Shower Mixer Faucet
- 2-Hole Installation: lever handle (cold & hot)

## FINISHES AVAILABILITY

PVD Warm Sunset

## AWARDS WON

- N/A

## SHIPPING WEIGHT

- Product gross weight: 8.0kg /set
- Product net weight: 5.93kg /set

## STANDARDS CRITERIA

- GB 18145-2014
- TIS2066-2552