

Maintenance

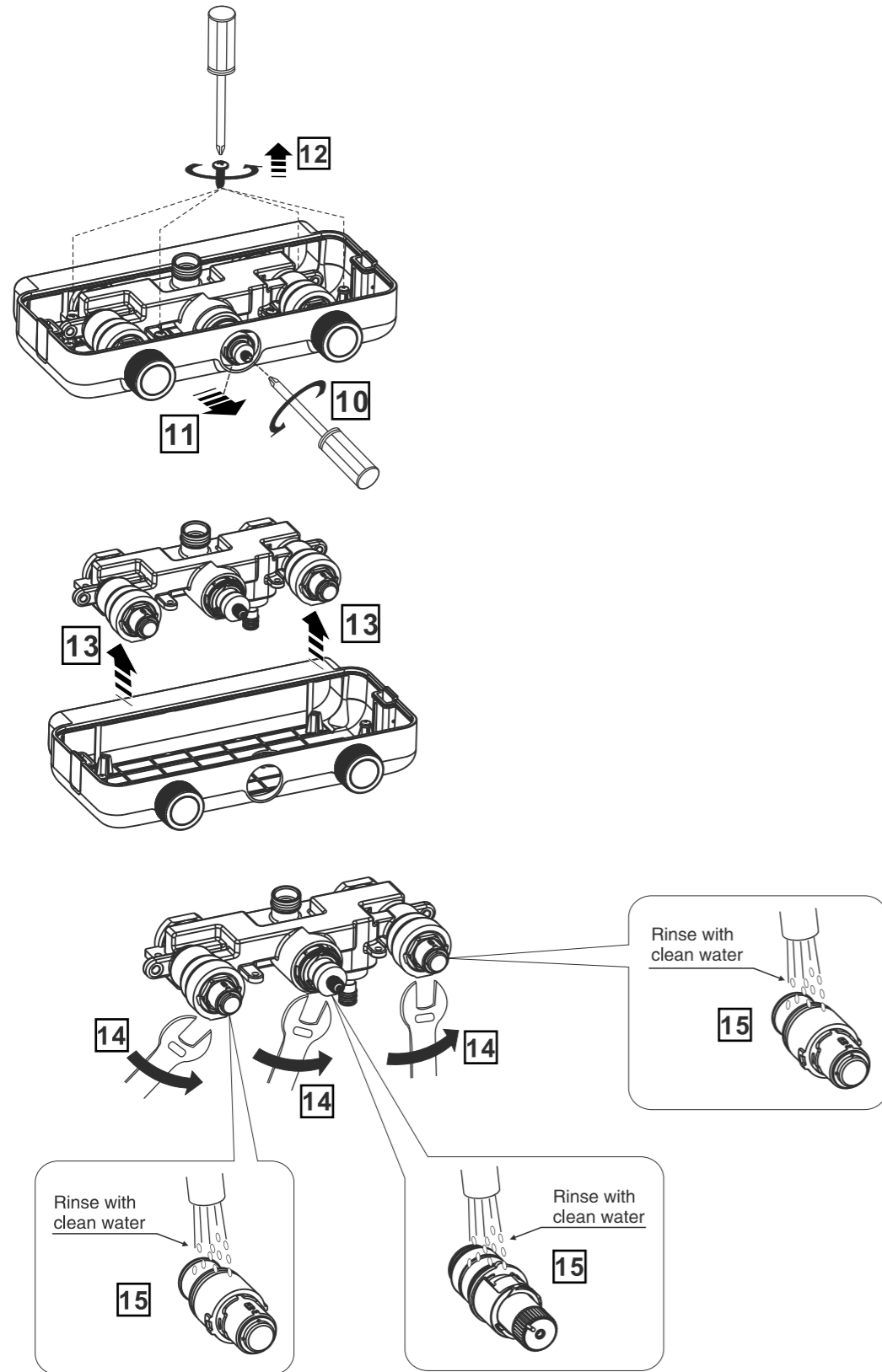

Attention:
Please leave manual with customer
post installation.

FFAS4955-701XXXBF0
FFAS4955-701XXXBT0
EasySET Exposed Auto Temperature Mixer
with Integrated Rain Shower Kit

XXX=AL0 / A00 / DA0 / GL0 / 440 / 500

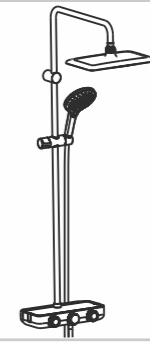

American Standard

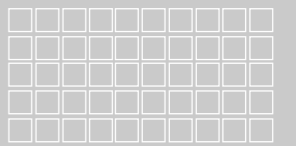

Installation &
Operation Instructions

Thank you for selecting American Standard the benchmark of fine quality for over 100 years.
To ensure that your installation proceeds smoothly, please read these instructions carefully before you begin.

- * American Standard continually improves our product design and performance and reserves the right to modify the dimension and specification of our products accordingly without any prior notification.
- * Actual dimensions and specifications may vary, refer to physical product for exact dimensions and specification.

Pre-Installation Checks

* Remove impurities from pipes before installation to avoid clogging. Connect faucet pipes correctly. Ensure that the cold water hose is connected to the right side and the hot water hose to the left. Check installation distances from the dimension diagram to ensure correct installation.

Conditions for use

1. Recommended water pressure condition: 0.1-0.5MPa (For optimal performance and product longevity, we recommend adding a pressure reducing valve when water pressure exceeds 0.5MPa. Difference in pressure between hot and cold water should not exceed 0.2MPa)
2. Water Temperature: Cold Water 4°C ~ 29°C; Hot Water 45°C ~ 85°C (Recommended Hot Water Temperature 50°C ~ 75°C).
3. Ambient Temperature: 1-55°C
4. Note: Ensure water source is clean. Poor water quality can cause cartridge and internal components to clog, resulting in poor temperature sensitivity and/or product failure.

Attention

Please ensure that the hot water supply source is stable. Electric water storage heaters are ideal for use with Temptation Auto Temperature Mixer for optimal performance. Common issues that may arise when hot water is supplied by gas and/or solar water heaters are as follows:

Common gas heater issue(s)

1. Every water heater has a minimum operational starting pressure (flow). When the lowest flow is selected with the mixer, the minimum operational starting pressure of the gas water heater may not be achieved and therefore, the gas heater will not function. When the residual hot water in the pipeline is discharged, the gas heater starts up, reheating the water. This repeated cycle results in an unstable hot water supply and inconsistent temperature delivery.

Solution:

- 1a. Set the water temperature of the water heater to 5°C higher than the thermostatic faucet (adjust with multiple manual knob, set the temperature knob in the lower position, and then use the knob to adjust the temperature of fire) the demand of hot water becomes larger in order to achieve the starting flow of the water heater. Recommended value: Summer: 45-50°C; winter 50-55°C.
- 1b. Set the water thermostatic faucet to full flow (half open water switch need to press the switch to rotate) you can also remove the limiting plug in the shower so that the water can become large to achieve the start flow of water heater.

Common solar heater issue(s)

2. As the solar water heater is not pressurized, hot water flows from to the mixer as a result of gravity. When the pressure from the cold water supply exceeds that of the hot water supply by 0.2MPa, hot water supply into the mixer is disrupted, resulting in inconsistent temperature delivery.

Solution:

- 2a. Add a pressure booster pump to the solar water heater so that the pressure of cold and hot water can be balanced. Push and save the pressurized water pressure: 0.3MPa.
- 2b. To add a pressure reducing valve on the cold water supply will also make the cold and hot water supply pressure balanced. When the water supply pressure exceeds 0.5MPa, the pressure relief valve is required. Recommended water pressure: 0.1-0.5MPa, hot and cold water pressure difference: less than 0.2MPa

Test / Usage

1 Test

1. Press buttons to turn on/ off water and check for water flow and any potential leakages.
2. Rotate knobs in all directions to ensure that knobs are moving smoothly and water volume changes accordingly.

2 Usage

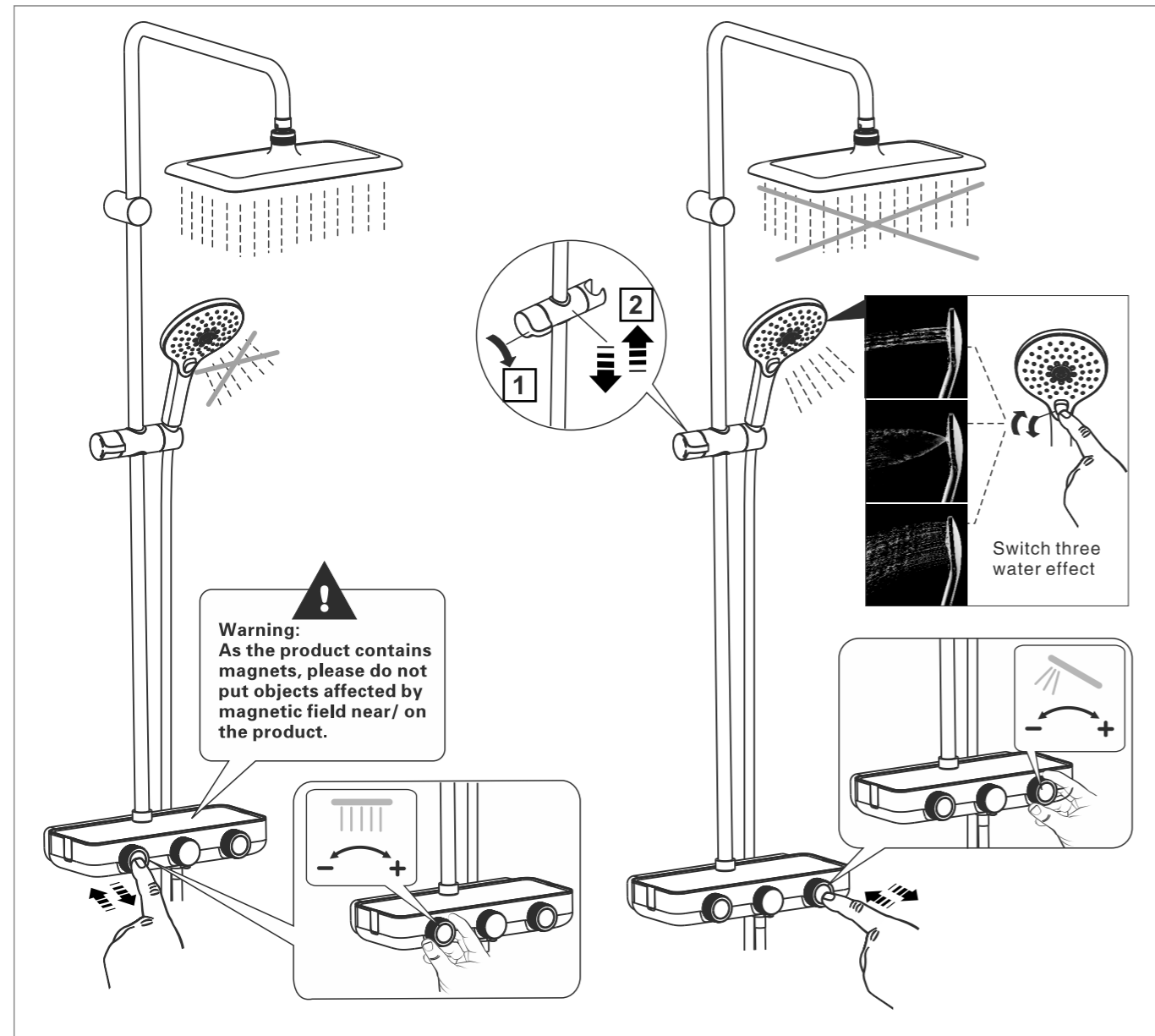

Parts List

No.	Part Name	Q' ty
1	S-connector	2
2	Check valve	2
3	Snap ring	2
4	O-ring	2
5	Anchor	6
6	Locating plate	1
7	Nut	2
8	Screw	6
9	Shower tray	1
10	Body	1
11	Screw	2
12	Hose	1
13	Temperature cartridge	1
14	Nut	1
15	Adaptor	1
16	Screw	1
17	Locating ring	1
18	Nut	1
19	Handle	1
20	Screw	1
21	Button	2
22	Locating ring	2
22a	Stop ring	2
23	Nut	2
24	Switch valve	2
25	O-ring	1
26	Nut	1
27	Pipe	1
28	Handle hanger	1
29	Hand shower	1
30	Screw	2
31	Bracket	1
32	Screw	1
33	Fixed seat	1
34	Anchor	1
35	Elbow pipe	1
36	Head shower	1
37	L-Wrench (2.5mm)	1
38	L-Wrench (5.0mm)	1
39	Magnet	2
40	Sucking Disc	2
41	Nut	2
42	Washer	2
A	Handle cover	1
B	Handle cover	1

