

2023年1月17日
A/O

Tolerance, Unless Otherwise Stated, Is			
Above 0.5 to and including 6	6		±0.1
Excess 6 to and including 30	30		±0.2
Excess 30 to and including 120	120		±0.3
Excess 120 to and including 315	315		±0.5
Excess 315 to and including 1000	1000		±0.8
Excess 1000 to and including 2000	2000		±1.2

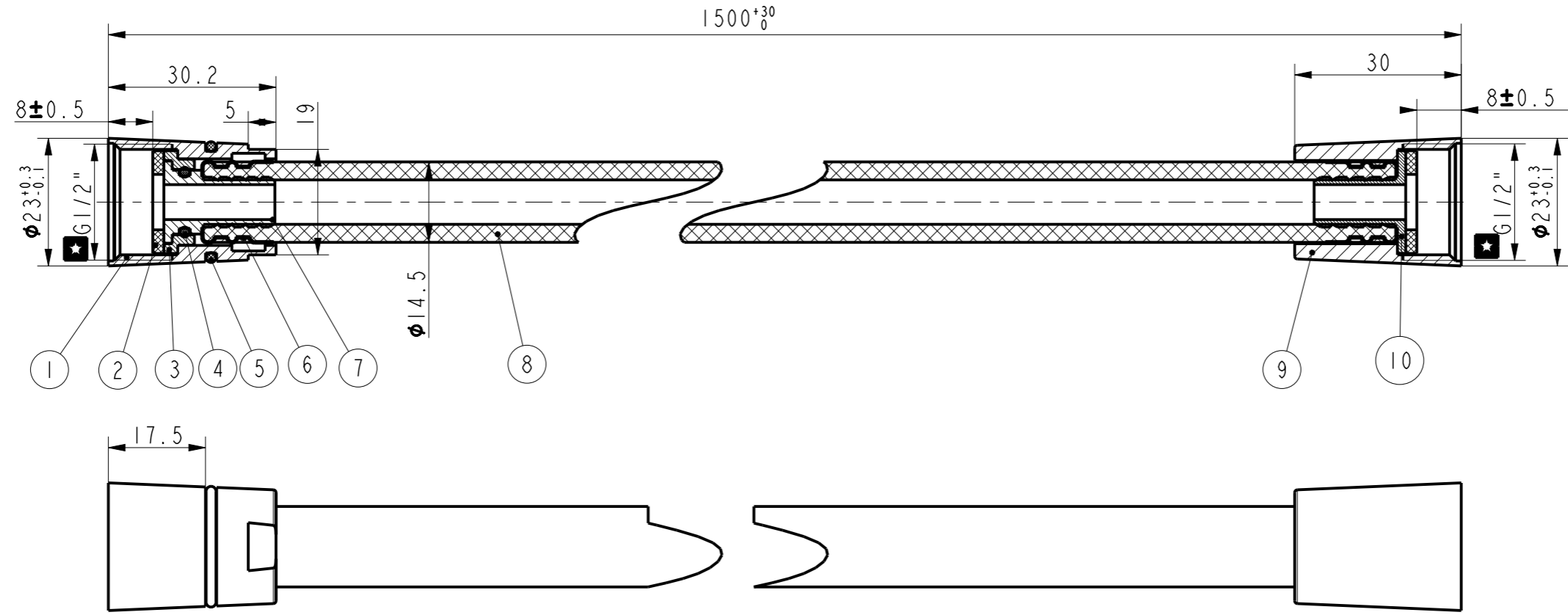

- 技术要求:
- 零件锐角倒钝, 去掉毛刺;
 - 螺纹表面不得有凹痕, 断牙等明显缺陷; G1/2" 螺纹须符合通规通, 止规止的要求;
 - 喇叭接头及PVC管颜色均为亚黑色, 具体参考封样件;
 - 喷粉后表面应结合良好, 组织细致紧密, 色泽均匀, 不应有明显的杂质, 孔洞, 碰伤和变形, 表面无烧伤素材, 无桔皮等现象;
 - 喷粉表面需符合内控标准《WI10.0589》中的规定;
 - 软管技术要求需符合内控标准《WI10.0407》中的规定;
 - 无塑包装, 两端接头用纸包好, 再将纸带将软管缠好;
 - 带"★"号为重要尺寸;

No.	Part No.	Description	QTY	Material	Remark
10	FF1-CN521T0004161P-10	内芯-2	1	HPb59-1	
9	FF1-CN521T0004161P-9	喇叭接头 (接进水)	1	HPb59-1	喷粉(亚黑)
8	FF1-CN521T0004161P-8	超柔亚黑管	1	PVC(亚黑)	
7	FF1-CN521T0004161P-7	内芯-1	1	HPb59-1	
6	FF1-CN521T0004161P-6	封套	2	SUS304	
5	FF1-CN521T0004161P-5	O环	1	NBR	黑色
4	FF1-CN521T0004161P-4	O环	1	EPDM	黑色
3	FF1-CN521T0004161P-3	压盖	1	HPb59-1	
2	FF1-CN521T0004161P-2	垫片	2	NBR	黑色
1	FF1-CN521T0004161P-1	喇叭接头(接花洒)	1	HPb59-1	喷粉(亚黑)

DESIGNED	刘卫群	2022.10.08	TITLE
CHECKED	张光强	2022.10.8	REF
APPROVED	郭守志	2022.10.8	1.5米防缠绕超柔手持花洒软管 (亚黑色)
SCALE	MATERIAL	WEIGHT	DWG NO.
1:1	组件	[.0]	FFAS9127-000440BF0

REV	DESCRIPTION	DATE	NAME

American Standard