

Tolerance, Unless Otherwise Stated, Is			
Above	0.5 to and including	6	±0.1
Excess	6 to and including	30	±0.2
Excess	30 to and including	120	±0.3
Excess	120 to and including	315	±0.5
Excess	315 to and including	1000	±0.8
Excess	1000 to and including	2000	±1.2

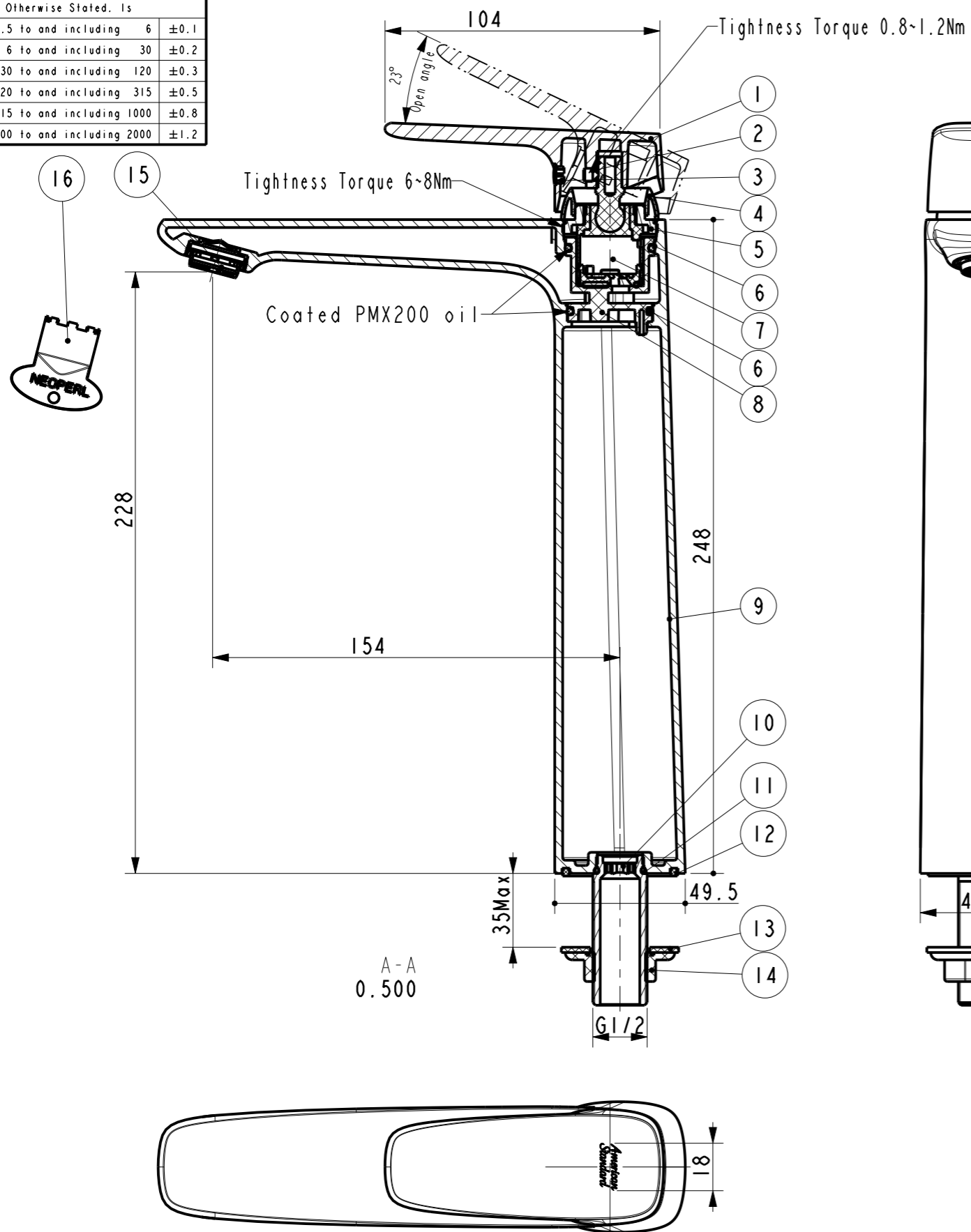

SCALE 0.200

Technical requirements

1. Cartridge tightening torque is 6~8 N.m and the other torque is implemented according to the W109.1520 assembly torque specification.
2. O-ring coated lubricating oil PMX200.
3. The product should meet the requirement «W110.0507 Internal Standard--Ceramic Cartridge Faucets for Thailand MKT»;

16	FF1-CN521A00000097	Allen Key	1	PA66-GF3	
15	FF1-CN521A0001799P	M24X1 SLIM Air SSR Aerator 1.5gpm	1	Assembly	
14	FF1-CN521N00002399	G1/2 Fixing Nut	1	ABS	
13	FF1-CN521G00000018	G1/2 Flat Washer	1	NBR	
12	FF1-CN521G00000067	Washer	1	NBR	
11	FF1-CN521G00000106	O-ring 13.8*2	1	NBR	
10	FF1-CN521J0013799S	Inlet Shank	1	SUS 304	
9	FFZZ0021-0023850PL	Body for Signatruie Extended Basin Mono	1	GkMs60Fk	CP
8	FF1-CN521J000008799	Manifold for 25# Cartridge	1	PPO	
7	FF1-CN521C00000011	25# Cartridge	1	Assembly	
6	FF1-CN521G000003299	O-Ring 26.64X2.62	2	NBR	
5	FF1-CN521N000002599	Cartridge Lock Nut	1	Hpb59-1	
4	FF1-CN521F00000041	Cartridge Cover	1	ABS	CP
3	FF1-CN521Z00004950	Plug for handle	1	ABS	CP
2	FF1-CN521N000000228	Handle Screw M5*6	1	SUS 304	
1	FF1-CN521L0006750X	Handle for Signature Mono	1	ZZnAl4-1	CP
NO.	Part No.	Part name	QTY	Material	Finish

DESIGNED			TITLE
CHECKED			REF
APPROVED			Signature Extended Basin Mono
SCALE	MATERIAL	WEIGHT	DWG NO.
1:2	Assembly		FFAS1707-1015LOBT0

American Standard

REV	DESCRIPTION	DATE	NAME