

Signature Signature 3/4.5lpf Wall Hung Toilet

Toilet

STYLE SEGMENT

- Modern

KEY SPECIFICATIONS

- Product Dimensions: L550*W382*H290 mm
- Installation Type: Wall Hung
- Flushing System: Double Vortex
- Flushing Platform: Washdown
- Flushing Type: Dual flush
- Flushing Volume: 3/4.5 litre per flush
- Trapway: S Trap & P Trap
- Rough In: 220 horizontal to wall only mm
- Trapway Design: Fully Skirted
- Bowl Shape: Elongated
- Water Pressure, Dynamic (MPa): 0.05 Megapascal
- Water Pressure, Static (MPa): 0.75 Megapascal
- Material: Vitreous China
- Color Availability: White Heat II



SHIPPING WEIGHT

- Net Weight: 20 kg
- Gross Weight: 23 kg

KEY TECHNOLOGIES AND FEATURES

HYGIENE

- Aqua Ceramic
- ComfortClean
- Double Vortex
- Hygiene Rim

COMFORT

- Comfort Curve Seat

CONVENIENCE

- Quick-Detach Seat Cover
- Easy Release
- Skirted Design
- Slow-Closing Seat & Cover

DURABILITY

- Complies with American Standard Quality Standards

SUSTAINABILITY

- Dual Flush
- Water-Saving

SAFETY

- Complies with American Standard Quality Standards

OTHERS

- NIL

STANDARDS AND CERTIFICATIONS

- GB 6952-2015

Signature

Signature 3/4.5lpf Wall Hung Toilet

Toilet

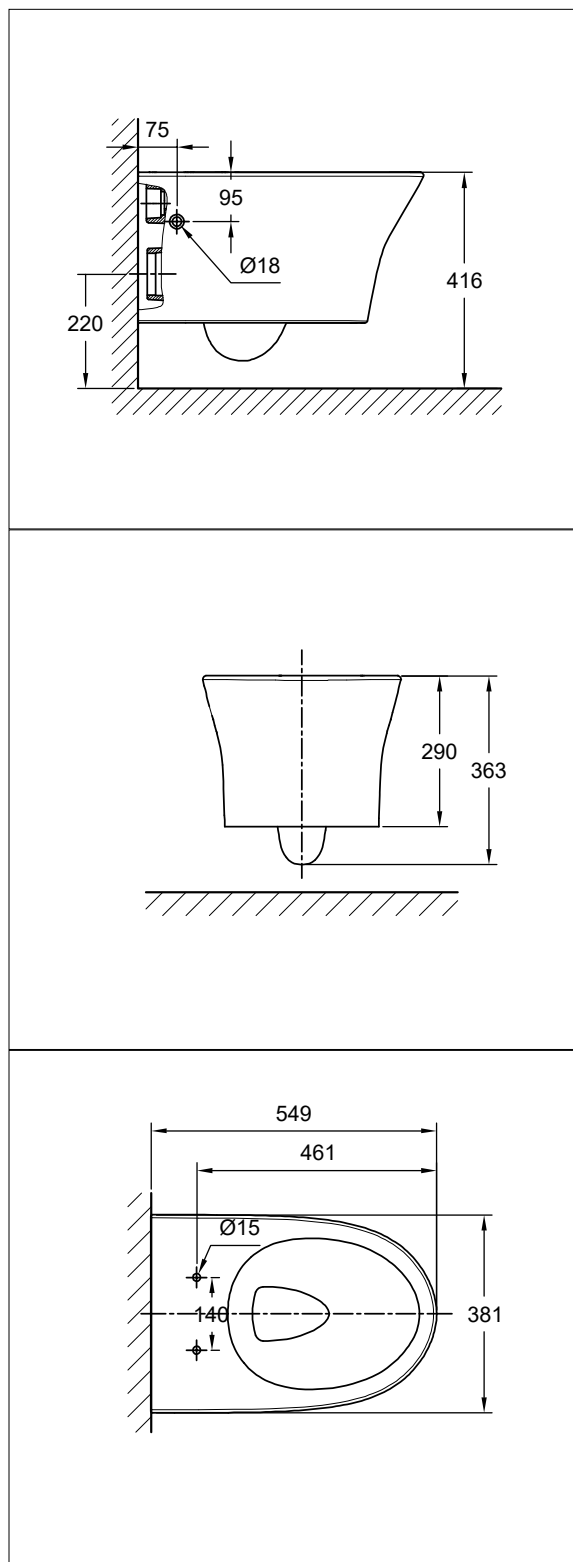

Signature

Signature 3/4.5lpf Wall Hung Toilet

Toilet

Item	Description	Signature 3/4.5lpf Wall Hung Toilet
Dimensions	Product (mm)	L550*W382*H290 mm
Material & Color	Material	Vitreous China
	Color	White Heat II
Bowl	Shape	Elongated
Trapway	Type	S Trap & P Trap
	Rough-in (mm)	220 horizontal to wall only mm
	Design	Fully Skirted
Flushing	System	Double Vortex
	Type	Dual flush
	Platform	Washdown
	Volume	3/4.5 litre per flush
Water Pressure	Dynamic (MPa)	0.05 Megapascal
	Static (MPa)	0.75 Megapascal
Installation	Type	Wall Hung
Components	Toilet Seat Included	Yes
Shipping	Net Weight (kg)	20 kg
	Gross Weight (kg)	23 kg
	Product Weight (kg)	20 kg
	Dimensions (mm)	L555*W387*H295 mm