

Test / Usage 测试和使用

1 Test 测试

- * Push lever down to 'OFF' position. Open water supply valve to check all connections for leakage(s).
- * Lift lever up to 'ON' position. Check that water is flowing from spout.
- * 将把手处在关的位置，开启供水并检查各连接是否有渗漏；
- * 打开把手，检查出水是否正常。

2 Usage 使用

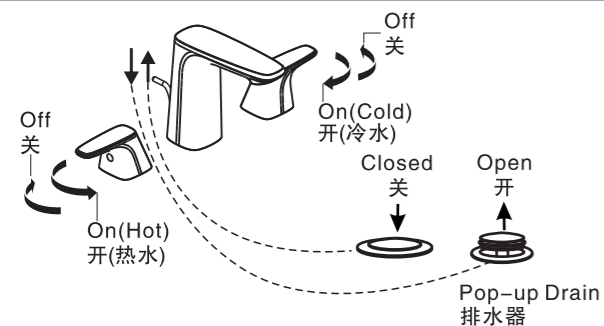

Warning:
When using the faucet, please turn on cold water first before turning on hot water gradually until desired water temperature is achieved.

注意:
使用双把手时，请先开启冷水，然后慢慢加入热水，直到温度合适。

Trouble Shooting Guide 一般故障排除指南

Issue 故障	Component 检查点	Checkpoint 内容	Corrective Action 处理办法
Poor flow rate 流量小	Aerator 起泡器	Check if aerator is clogged 检查是否有杂质	Remove all impurities 清除杂质
	Water supply valve 供水阀	Check lever position 检查供水阀是否开得太小	Lift lever to maximise water volume 开大供水阀
	Hose 软管	Check if hose is twisted 检查软管是否扭曲	Untwist the hose 展开软管
Leakage 漏水	Cartridge 阀芯	Check if cartridge is loosened 检查阀芯是否被松开	Fasten or replace cartridge 紧固好阀芯
	Connection joints 各连接处	Check the connection 检查连接处是否未加垫片或垫片已损坏	Reassemble connecting part 重新安装
Abnormal Temperature 不正常水温	Water supply valve 供水阀	Check lever position 检查供水阀是否开得太小	Lift lever to maximise water volume 开大供水阀
	Water supply pipeline 供水管路	Check if supply pipes have been correctly connected 检查进水管是否连接正确	Connect the hot and cold water pipe correctly 正确连接冷热水管

Care & Maintenance 维护与保养

- * Clogged aerator due to poor water quality can lead to reduced water flow. Follow steps below to clean aerator to ensure optimal performance.
- * 起泡器可能积累污垢致损害或影响出水效果，此时应清洁或更换起泡器。

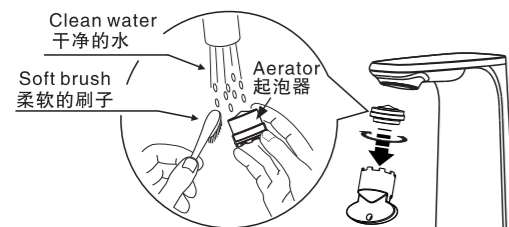

- * Clogged cartridges due to poor water quality can affect product performance.
- * Follow steps below to maintain optimal product performance.
- * Note: please turn off water supply before maintenance process.
- * 阀芯入口堵塞会导致冷、热水流量减少影响水流效果。
- * 请按照以下步骤维护，使产品达到最佳性能。
- * 注意：维护前，请先关闭供水。

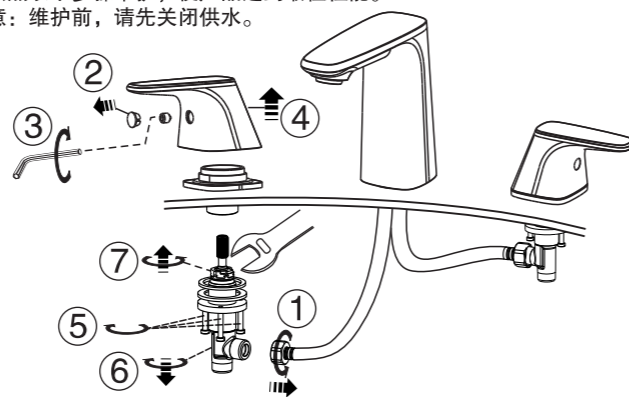

Attention:
Please leave manual with customer post installation.

安装者注意:
安装完成后，请将此说明书留给用户。

Signature 纤格

FFAS1703-1015L0BC0
Signature 3-Hole Basin Mixer With Pop-up Drain
纤格双柄双控面盆龙头（带去水器）

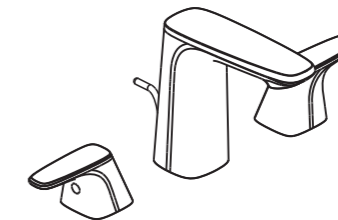

American Standard

Installation & Operation Instructions
安装/使用说明书

Thank you for selecting American Standard the benchmark of fine quality for over 100 years. To ensure that your installation proceeds smoothly, please read these instructions carefully before you begin.

- * American Standard continually improves our product design and performance and reserves the right to modify the dimension and specification of our product accordingly without any prior notification.
- * Actual dimensions and specifications may vary, refer to physical product for exact dimensions and specification.

感谢您选购美标洁具—拥有百年优质水准的产品，为保证安装顺利，请在进行安装前细阅以下指南

- * 美标公司一贯奉行不断提高和改善其产品设计及性能的政策，并保留对其产品规格更改的权力，届时，恕不另行通知。
- * 本指南仅供安装和使用作参考，产品以实物为准。

Pre-Installation Checks 安装前注意事项

- * Remove all impurities from pipes before installation to avoid clogging. Connect faucet pipes correctly. Ensure that the cold water hose is connected to the right side and the hot water hose to the left.
- * Check installation distances shown in the dimension diagram to ensure correct installation.
- * Warning: Avoid lifting/ holding product lever only during installation. Instead, hold product spout/ main body.

Conditions for use

- * Water pressure condition: 0.05~0.75MPa (Recommended water pressure condition: 0.1~0.5MPa)
- * Ambient temperature: 1~55°C
- * Water temperature: 4°C ~ 90°C (Recommended hot water temperature 50~60°C)
- * Steam should not be used with product.
- * Note: Ensure water source is clean. Poor water quality can cause cartridge and internal components to clog, resulting in poor volume control and/ or product failure.
- * 安装龙头之前，请务必清理管中杂物，以免造成堵塞；龙头与冷、热水管必须连接正确。
- * 参考尺寸图，检查安装尺寸，确保安装正确。
- * 安装时，请握住龙头主体进行操作，不要仅握住把手进行操作，以免损伤龙头。

使用条件

- ~ 使用水压（包括冷水与热水压力）：0.05~0.75兆帕，推荐使用水压：0.1~0.5兆帕。
- ~ 使用环境温度：1~55°C。
- ~ 使用水温度：4°C~90°C，建议使用热水的温度为50~60°C。
- ~ 不可使用蒸汽。
- ~ 使用水源：市政饮用水。（请确保水源清洁，低质量的水会导致阀芯或内部组件堵塞，影响产品性能。）

Recommended Tools and Materials 推荐的工具和材料



Dimension 基本尺寸

Unit: mm
单位：毫米

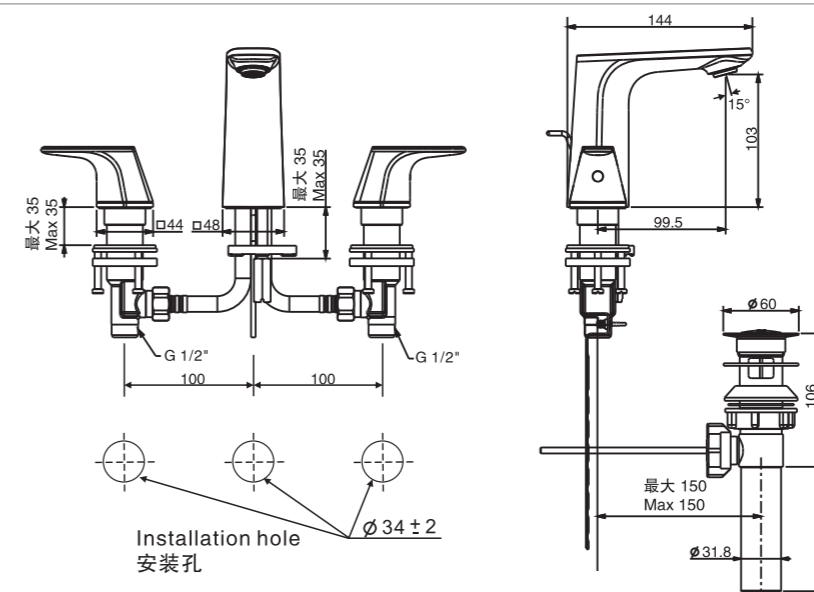

Parts List 零件明细

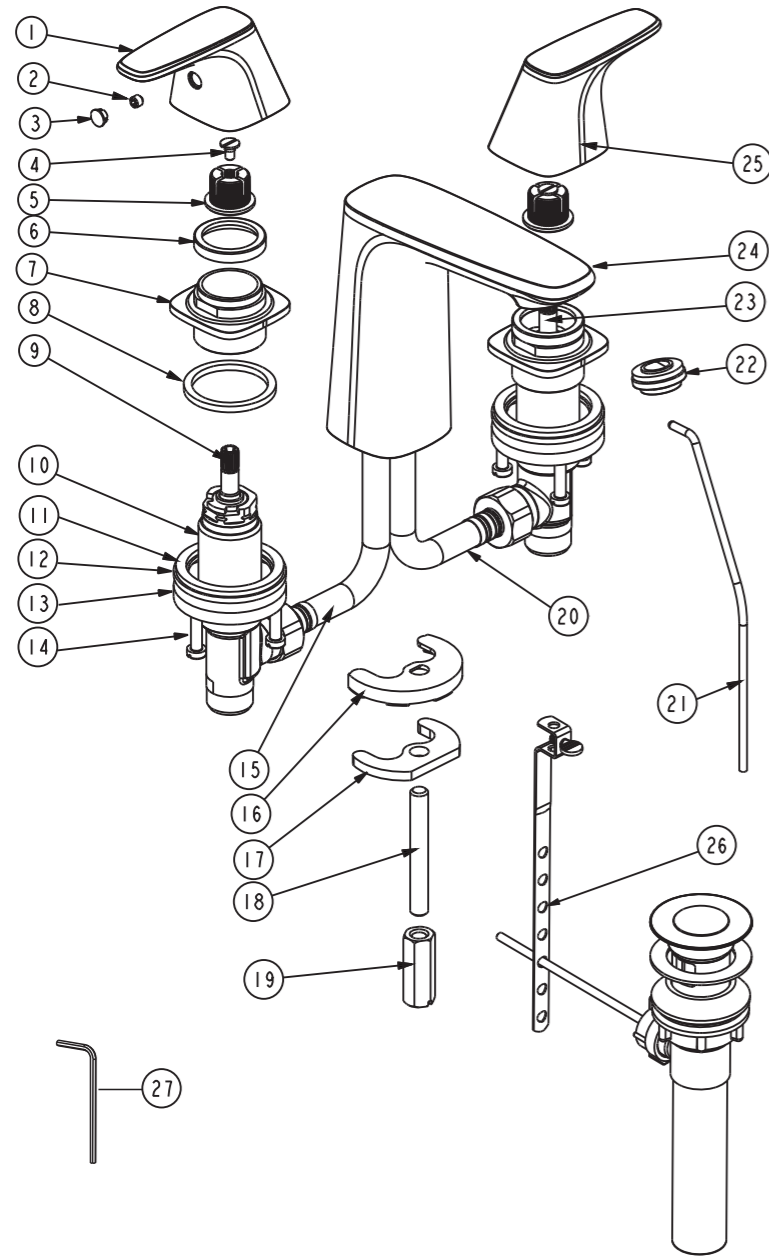

Parts List 零配件明细表		
No. 序号	Part Name 零件名称	Q'ty 数量
1	Lever 把手	1
2	Screw 螺丝	2
3	Index button 标志扣	2
4	Screw 螺丝	2
5	Bushing 阀杆衬套	2
6	Washer 垫圈	2
7	Nut 螺母	2
8	Washer 垫圈	2
9	Cartridge (left) 阀芯 (左)	1
10	Valve seat 阀座	2
11	Washer 垫片	2
12	Washer 垫片	2
13	Nut 螺母	2
14	Screw 螺丝	6
15	Hose(red) 连接软管(红)	1
16	Rubber gasket 橡胶垫片	1
17	Metal gasket 金属垫片	1
18	Shank 牙管	1
19	Nut 螺母	1
20	Hose(blue) 连接软管(蓝)	1
21	Lever 拉杆	1
22	Aerator 起泡器	3
23	Cartridge (right) 阀芯 (右)	1
24	Spout 出水体	1
25	Lever 把手	1
26	Pop-up drain 排水器	1
27	In-hex wrench 内六角扳手(2.5mm)	1

2 Faucet Installation 安装龙头

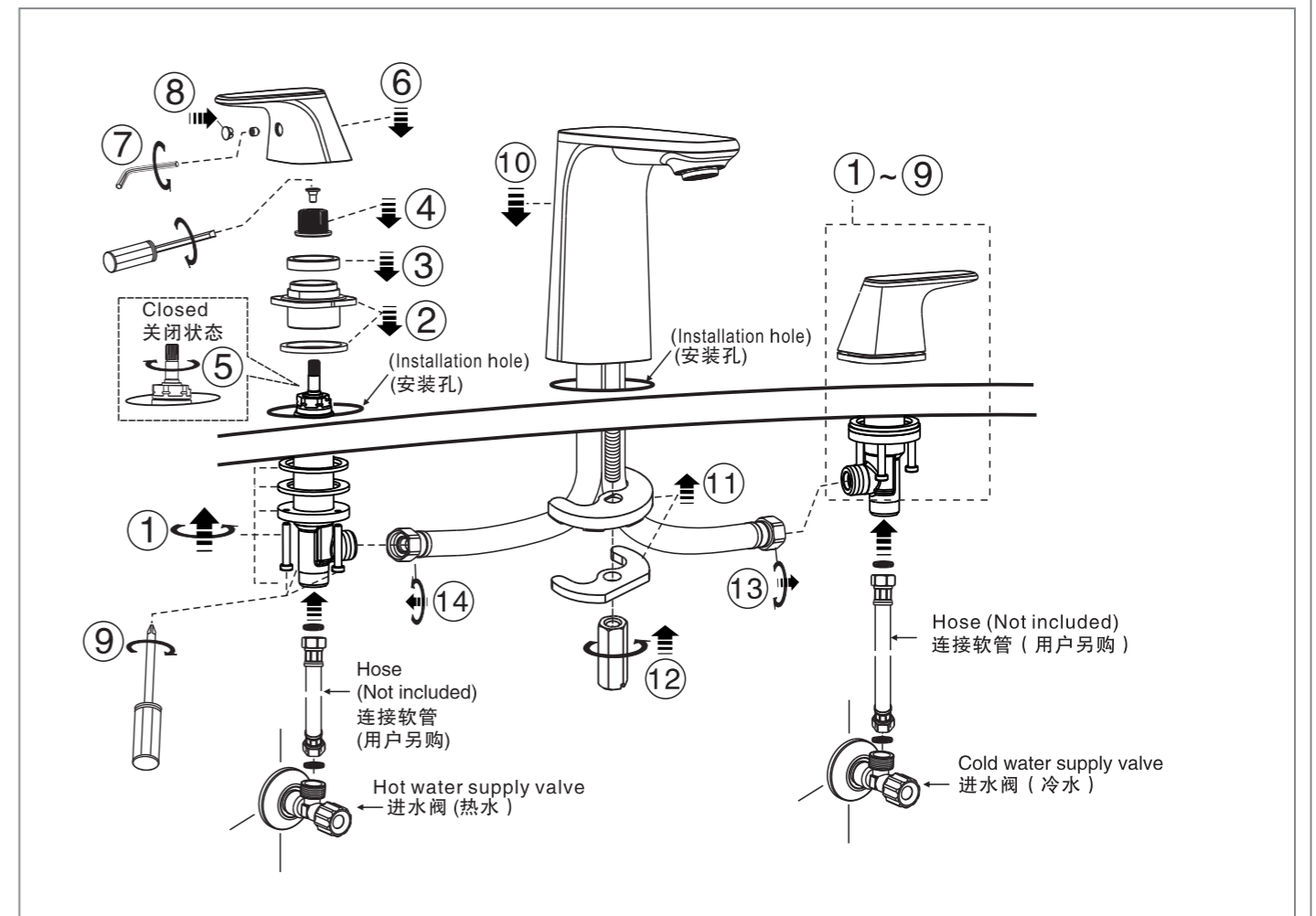

3 Pop-up Drain Installation 安装排水器

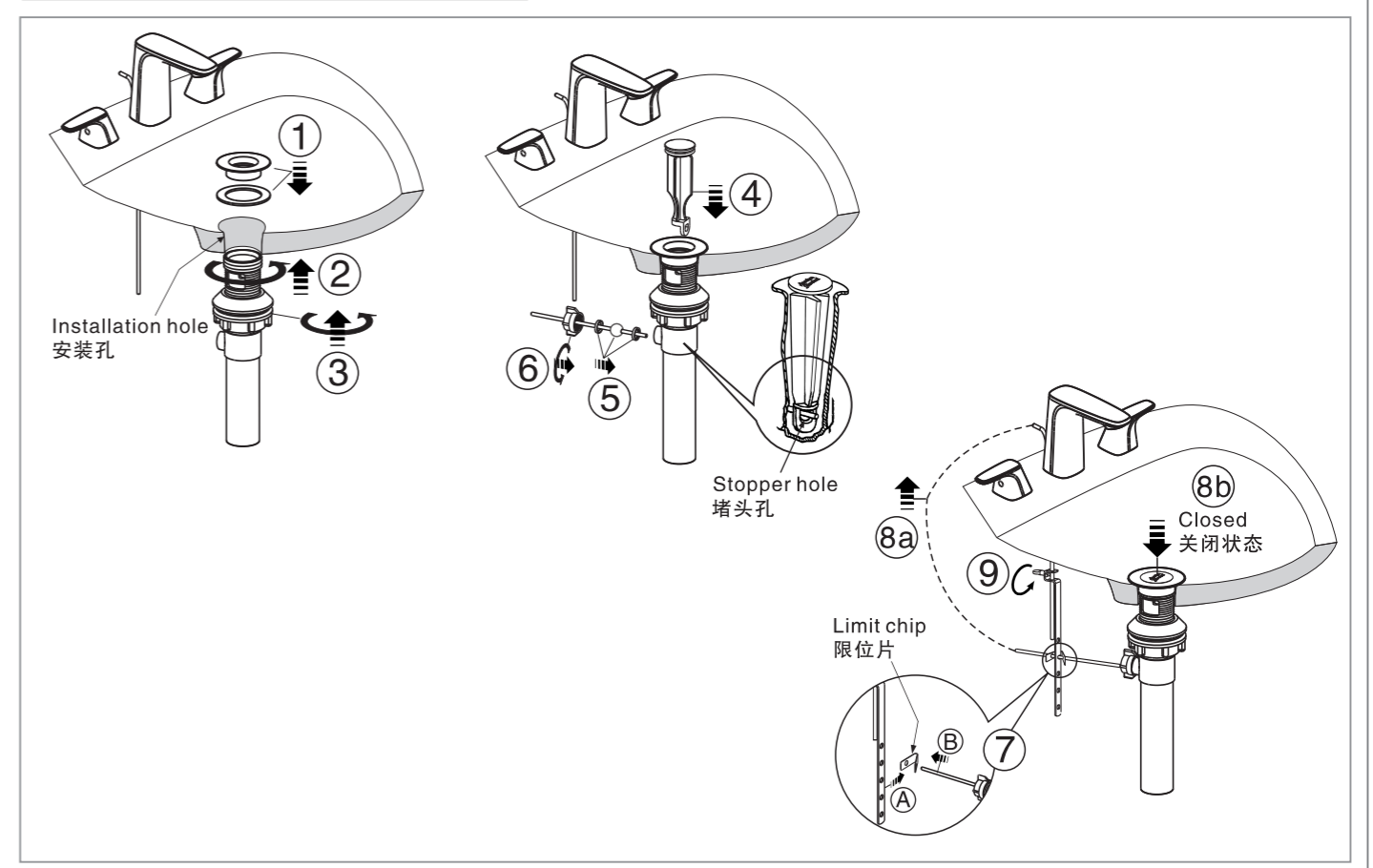

Installation 安装部分

1 Preparation 安装前准备

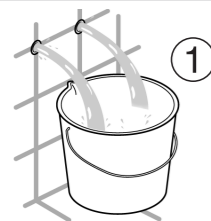

- * Lay cold & hot supply pipes based on dimension drawing.
- * Before installation, the laying of pipeline is rinsed clean.
- * 参考尺寸图, 铺设冷、热供水管路。
- * 安装前, 请将铺设的管路冲洗干净。

