

Tolerance, Unless Otherwise Stated, Is				
Above	0.5 to and including	6	±0.1	
Excess	6 to and including	30	±0.2	
Excess	30 to and including	120	±0.3	
Excess	120 to and including	315	±0.5	
Excess	315 to and including	1000	±0.8	
Excess	1000 to and including	2000	±1.2	

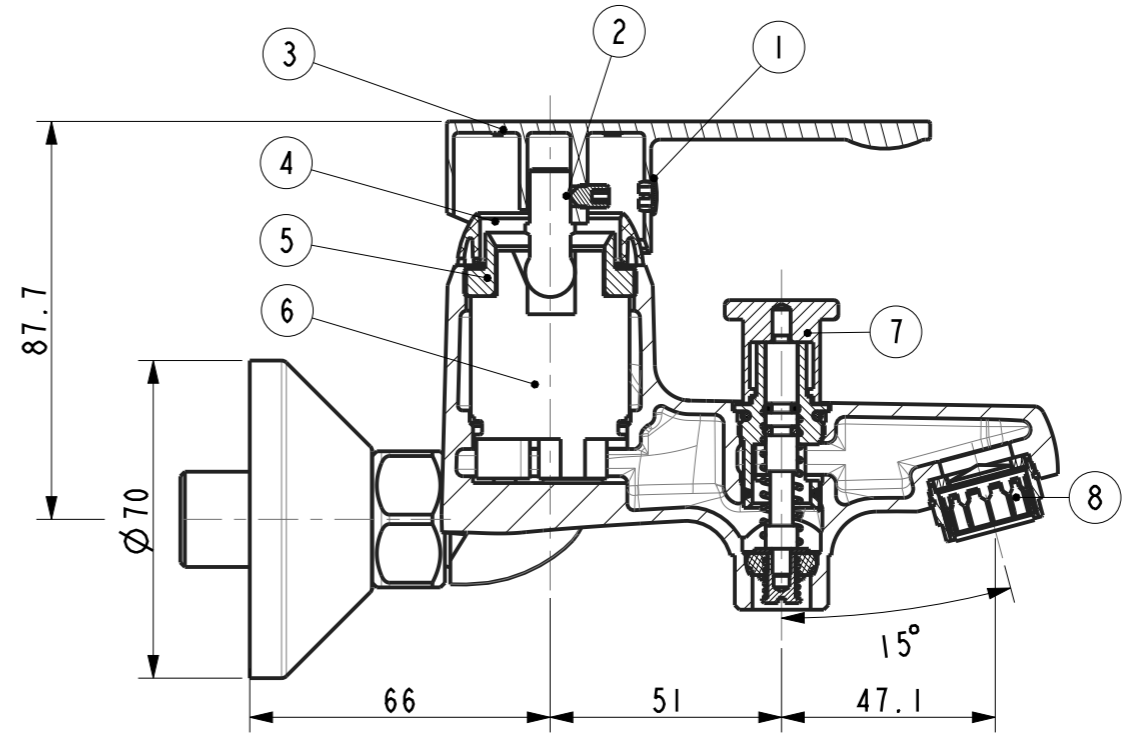
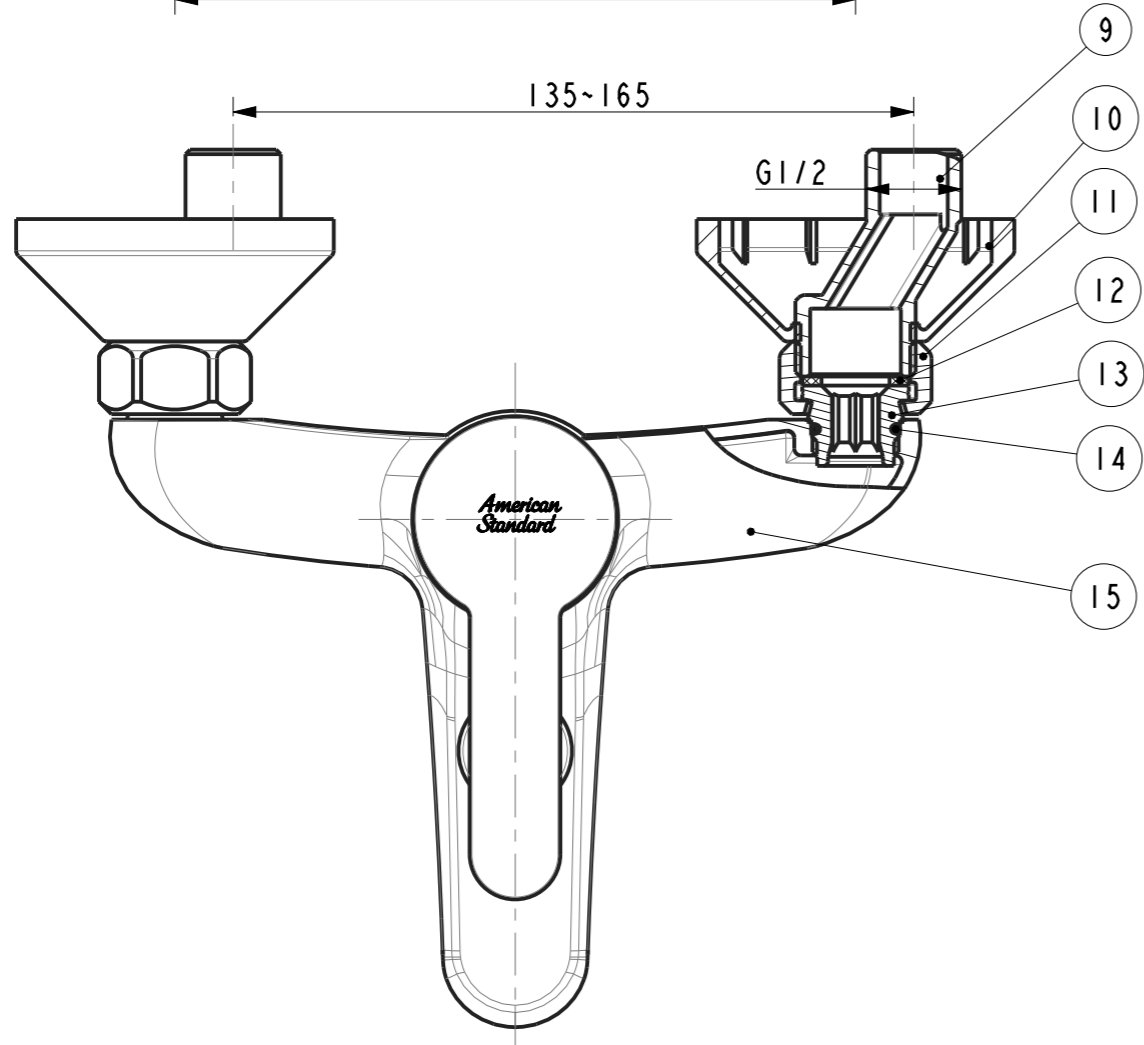
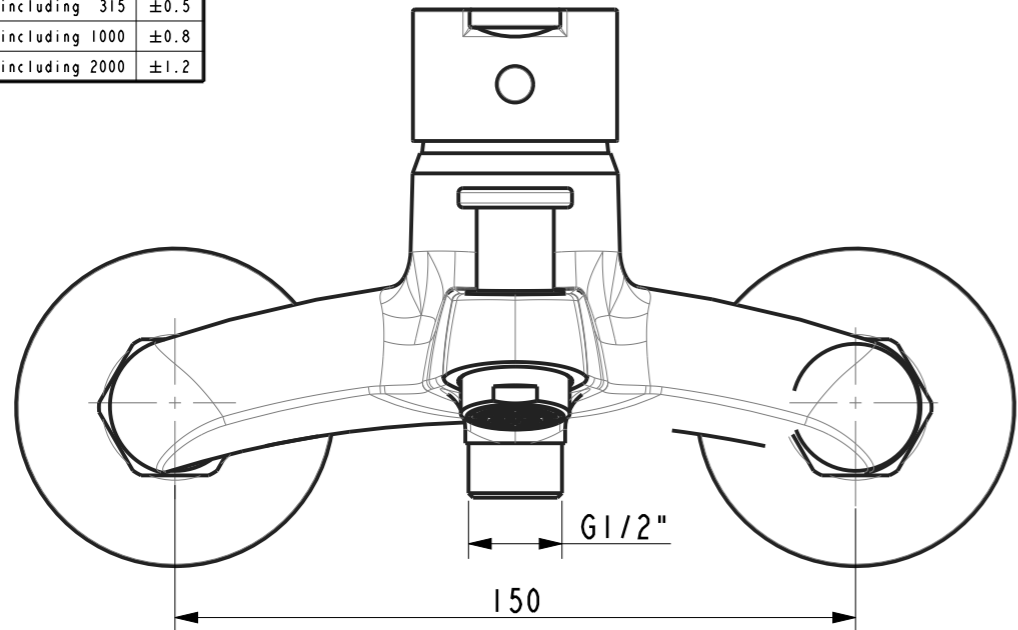

15	FFZZ6511-60150ZDPL	Body	GkMs60Fk	1	
14	FF1-CN521G00000112	O Ring 15.6*1.78	NBR	2	
13	FF1-CN521W00000048	THREADED NIPPLE	SUS304	2	
12	FF1-CN521G00000341	Washer $\Phi 24 * \Phi 15 * 2$	NBR	2	
11	FF1-CN521N00000291	Nut G3/4	HPb59-1	2	
10	FF1-CN521F00000094	Escutcheon	ABS	2	
9	FF1-CN521J00000242	S Connector(G1/2-G3/4)	SUS304	2	
8	FF1-CN521A00000050	Aerator	Component	1	
7	FF1-CN521X00000119	Diverter	Component	1	
6	FF1-CN521C00001399	Cartridge 35mm	Component	1	
5	FF1-CN521N00000068	Cartridge Nut	SUS304	1	
4	FF1-CN521F00000054	Cartridge Cover	ABS	1	
3	FF1-CN521L00000072	Handle	ZZnAl4-1	1	
2	FF1-CN521N000000899	Screw M5	SUS304	1	
1	FF1-CN521Z00000072	Handle Cover	ABS	1	
No.	Part Code	Description	Material	Qty	Remark

DESIGNED			TITLE		
CHECKED			REF		
APPROVED			Seva Exposed Bath & Shower Mixer without Shower Kit		
SCALE	MATERIAL	WEIGHT	DWG NO.		
3:5	Assembly		FFAS6511-6P3500BP0		

REV	DESCRIPTION	DATE	NAME

**American Standard**