

Tolerance, Unless Otherwise Stated, Is			
Above	0.5 to and including	6	±0.1
Excess	6 to and including	30	±0.2
Excess	30 to and including	120	±0.3
Excess	120 to and including	315	±0.5
Excess	315 to and including	1000	±0.8
Excess	1000 to and including	2000	±1.2

激光印 AS_Logo, 字宽 18,
具体见《WI09.2127》-概念浴室配件印字作业要求

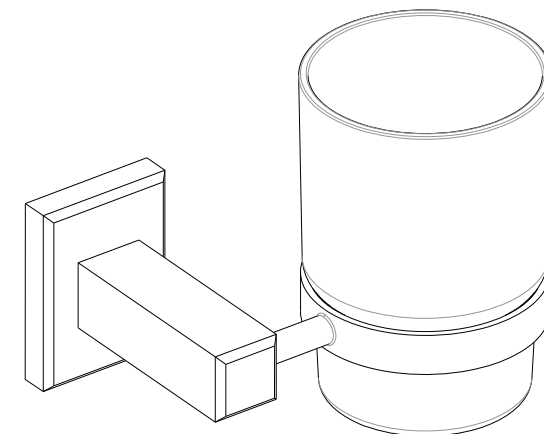

SCALE 0.500

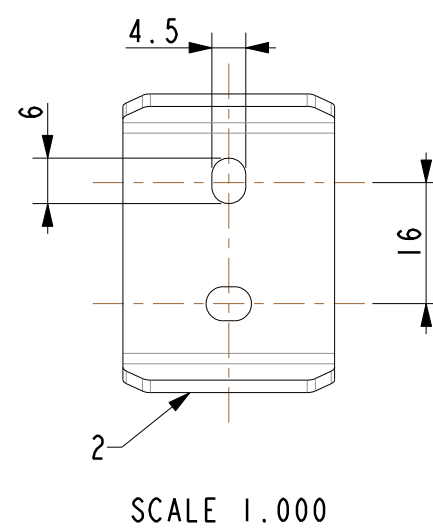
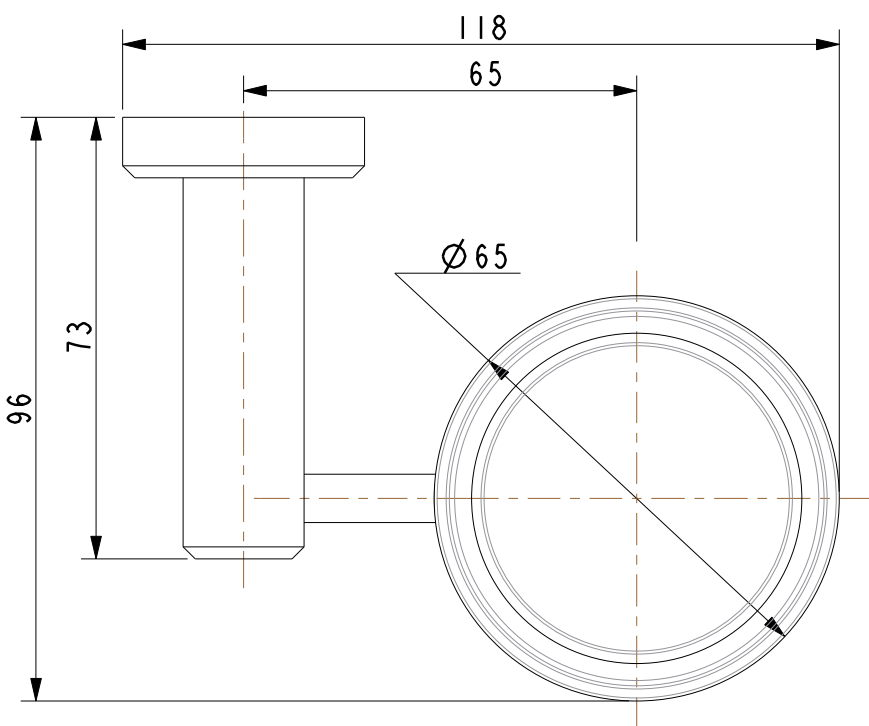
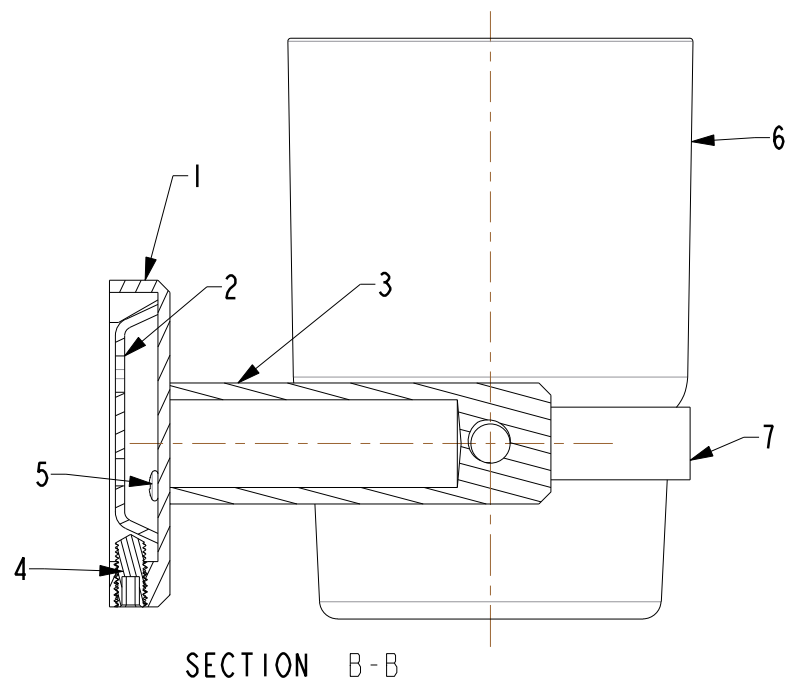
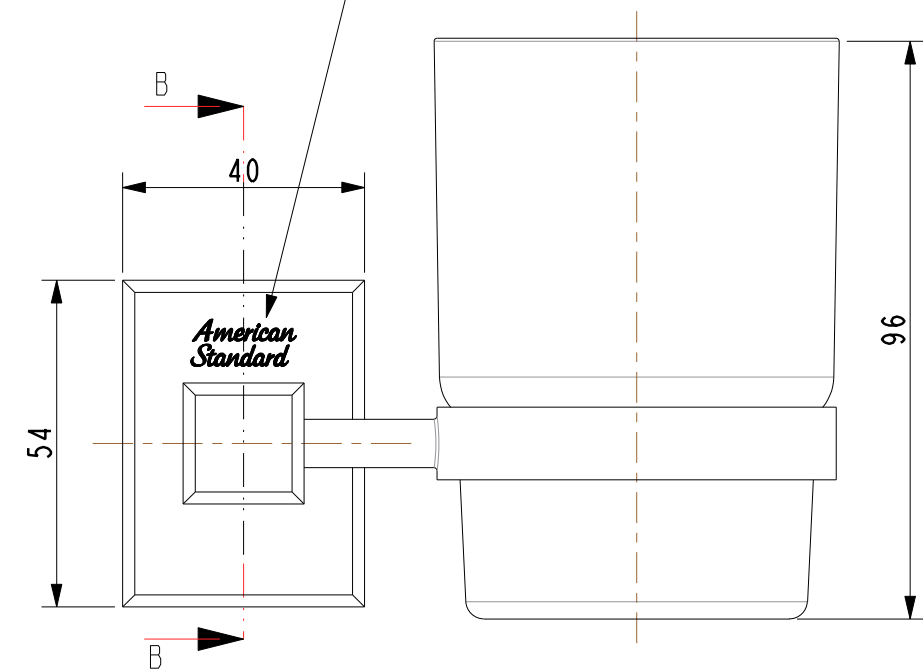
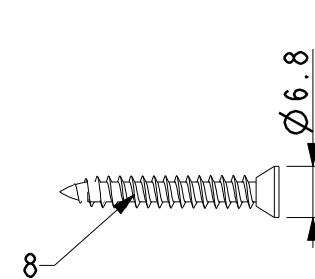

SCALE 1.000

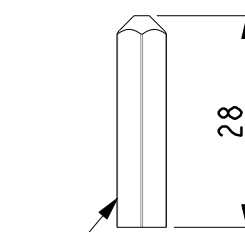

SCALE 1.000

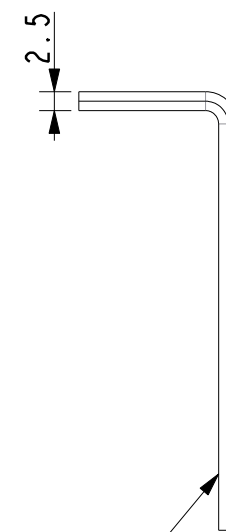

SCALE 1.000

技术要求:

- 按《WI10.3204》浴室配件进货检验标准检验;
- 所有尺寸为一般尺寸。

序号	料号	名称与描述	材料	数量	备注
10	159Z148108	内六角扳手2.5	Q235-A	1	
9	159Z148107	胀套	PA66	2	
8	159Z148106	自攻螺钉ST4*28	SUS201	2	
7	159Z048203	托架	ZZnA14-1	1	
6	159Z048402	杯子	钢化玻璃	1	磨砂
5	159Z048105	本体螺钉M3*7.5	SUS201	2	
4	159Z048104	支座螺钉M5*12	SUS201	1	
3	159Z048201	概念方本体	Hpb59-1	1	抛光镀铬
2	159Z048102	概念方固定垫片	SUS201	1	
1	159Z048101	概念方支座	ZZnA14-1	1	抛光镀铬

DESIGNED			TITLE
CHECKED			REF
APPROVED			概念方单杯架
SCALE	MATERIAL	WEIGHT	DWG NO.
0.800	Assembly		FFAS0484-908500BC0

American Standard

REV	DESCRIPTION	DATE	NAME