

Tolerance, Unless Otherwise Stated. Is			
Above	0.5 to and including	6	±0.1
Excess	6 to and including	30	±0.2
Excess	30 to and including	120	±0.3
Excess	120 to and including	315	±0.5
Excess	315 to and including	1000	±0.8
Excess	1000 to and including	2000	±1.2

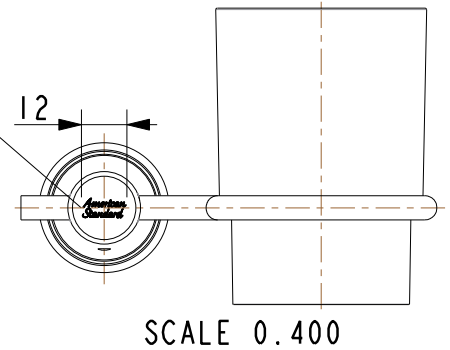

SCALE 0.400

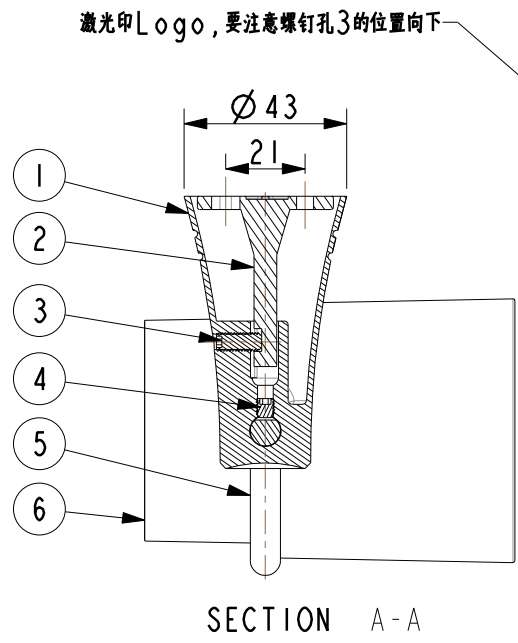
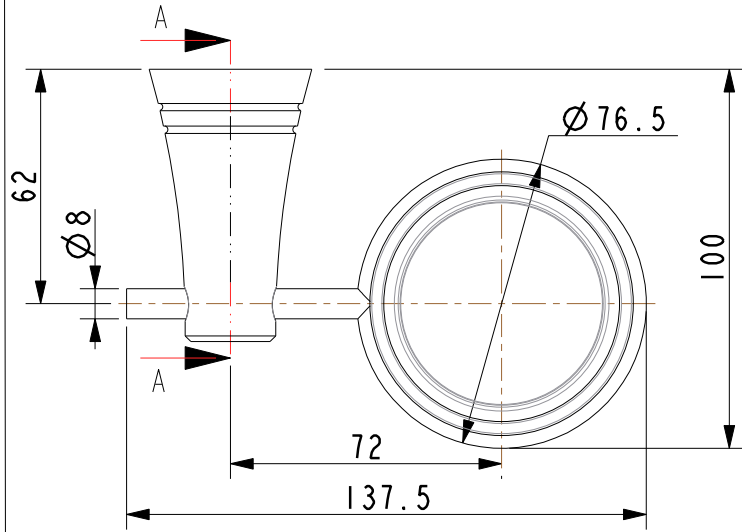
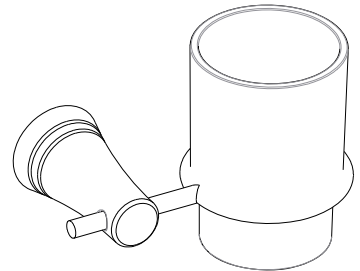
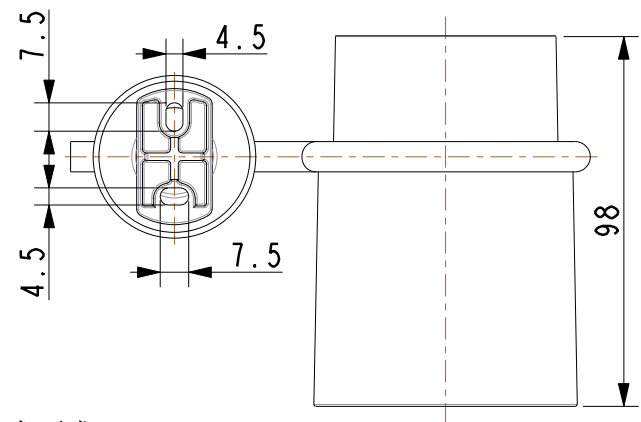
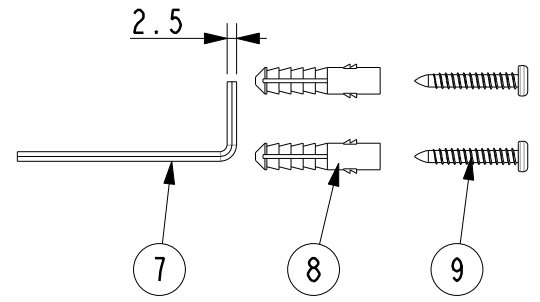

SCALE 0.300

技术要求:
1. 按进料检验标准 WI10.3204 《浴室配件》进行检验。
2. 图示所有尺寸为成品尺寸, 要求是一般尺寸。

序号	品名	数量	材料	备注
9	胀套螺钉	2	SUS 304	ST4.0*40
8	胀套	2	POM	φ 7.5*37
7	六方扳手	1	SUS 304	
6	杯子	1	Acryl	透明
5	托架	1	ZZnA14-1	镀铬
4	固定螺钉(短)	1	SUS 304	
3	固定螺钉(长)	1	SUS 304	
2	支座	1	ZZnA14-1	镀铬
1	本体	1	ZZnA14-1	镀铬

DESIGNED		TITLE	
CHECKED		REF	
APPROVED		塞弗杯架	
SCALE	MATERIAL	WEIGHT	DWG NO.
0.500	Assembly		FFAS6583-908500BF0
			<i>American Standard</i>

REV	DESCRIPTION	DATE	NAME