

F11302-CHACT102

Acacia Evolution

ACACIA E VESSEL MIXER

STYLE SEGMENT

- Modern

KEY SPECIFICATIONS

- Product Description: Vessel Basin Mixer
- Colour: Chrome
- Faucet Type: Mixer
- No. of Faucet Holes Required: 1
- Flow Rate: 3.6
- Is Drain Included: No
- Connection Size (inches): G1/2



SHIPPING WEIGHT

- Net Weight: 2.6
- Gross Weight: 2.8

KEY TECHNOLOGIES AND FEATURES

HYGIENE

- Complies with American Standard Quality Standards

COMFORT

- Complies with American Standard Quality Standards

CONVENIENCE

- Complies with American Standard Quality Standards

DURABILITY

- Complies with American Standard Quality Standards

SUSTAINABILITY

- Complies with American Standard Quality Standards

SAFETY

- Complies with American Standard Quality Standards

OTHERS

- NIL

STANDARDS AND CERTIFICATIONS

- GB 18145-2014
- TIS 2067-2544

F11302-CHACT102

Acacia Evolution

ACACIA E VESSEL MIXER

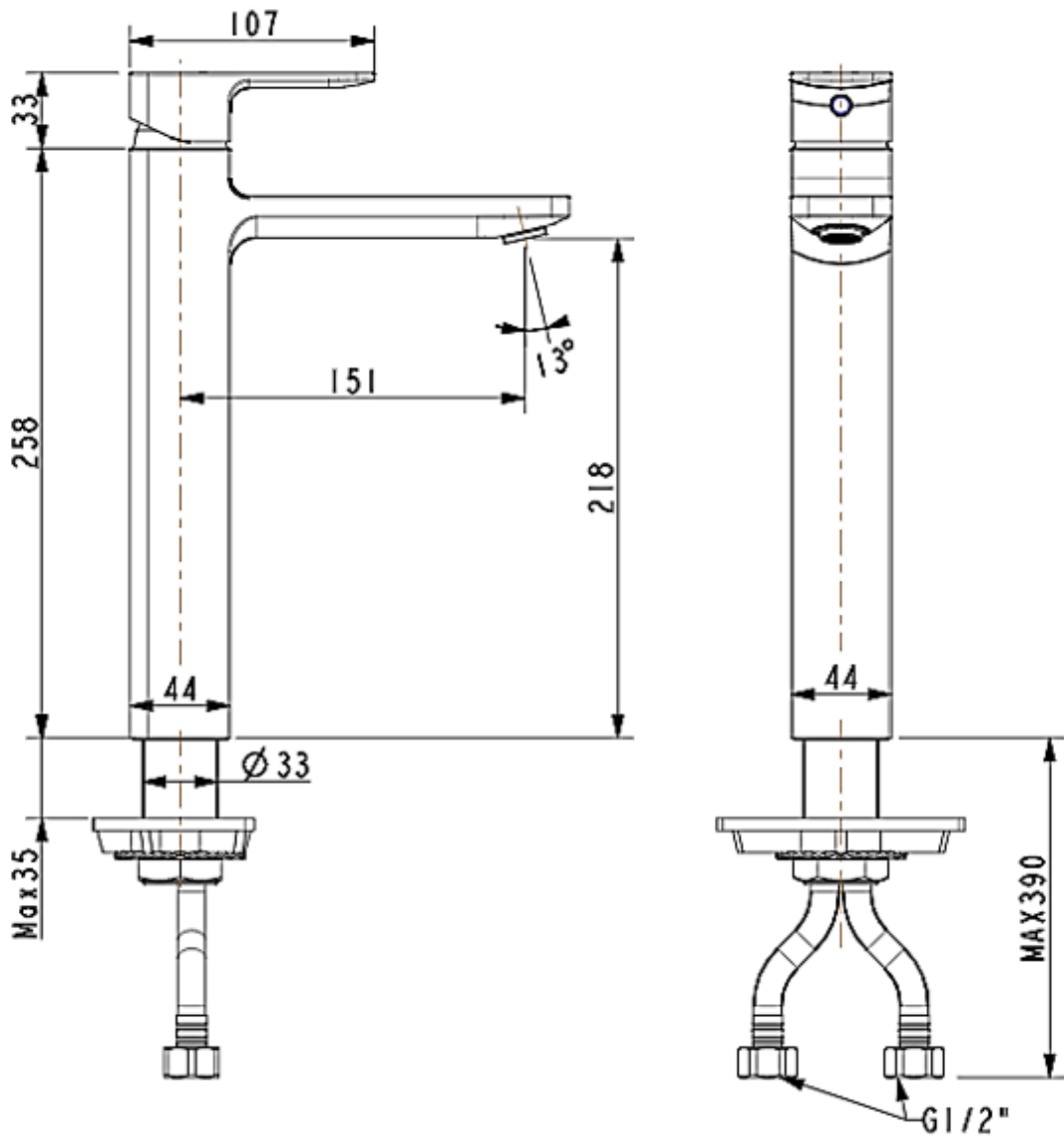

F11302-CHACT102

Acacia Evolution

ACACIA E VESSEL MIXER

Product	Description	Vessel Basin Mixer
	Weight (kg)	3.1
	Finish	Chrome
	Flow Rate	3.6
	Mounting Location	Deck Mount
Material & Color	Material	Brass
	Color	Chrome
Faucet	Type	Mixer
	No. of Holes Required	1
Connection	Size (mm)	G1/2
	Size (inches)	G1/2
Handle	Material	Zinc Die Cast
	Type	Lever
	No. of Handles	1
Components	Drain Included	No
	Included	long handle & aerator key
	Excluded	drain
Spout	Hose Thread in Spout	No
	Dimensions (mm)	Spout Reach: 151
	Type	Ceramic
Valve	Type	Integrated