

CCAS0628-0000410F0

## Signature

### Signature 550mm Vessel

#### STYLE SEGMENT

- Modern

#### KEY SPECIFICATIONS

- Installation Type: Vessel
- Product Dimensions: 550 x 400 x 100
- Material: Vitreous China
- Color: White
- Overflow Hole: Without
- Faucet Ledge: No
- Included Components: No



#### SHIPPING WEIGHT

- Net Weight: 13
- Gross Weight: 13

#### KEY TECHNOLOGIES AND FEATURES

##### HYGIENE

- Complies with American Standard Quality Standards

##### COMFORT

- Complies with American Standard Quality Standards

##### CONVENIENCE

- Complies with American Standard Quality Standards

##### DURABILITY

- Complies with American Standard Quality Standards

##### SUSTAINABILITY

- Complies with American Standard Quality Standards

##### SAFETY

- Complies with American Standard Quality Standards

##### OTHERS

- NIL

#### STANDARDS AND CERTIFICATIONS

- GB/T 6952-2015

CCAS0628-0000410F0

Signature

Signature 550mm Vessel

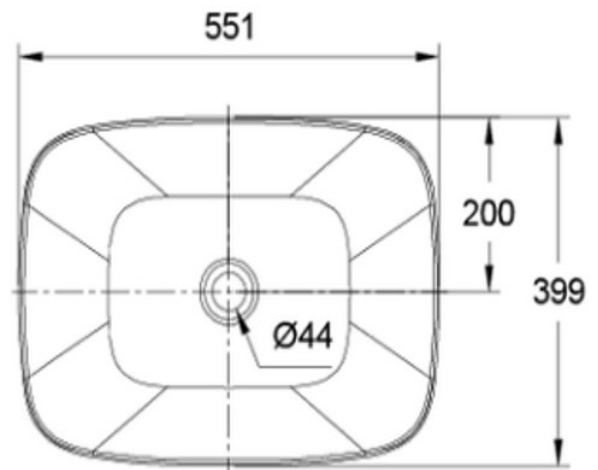
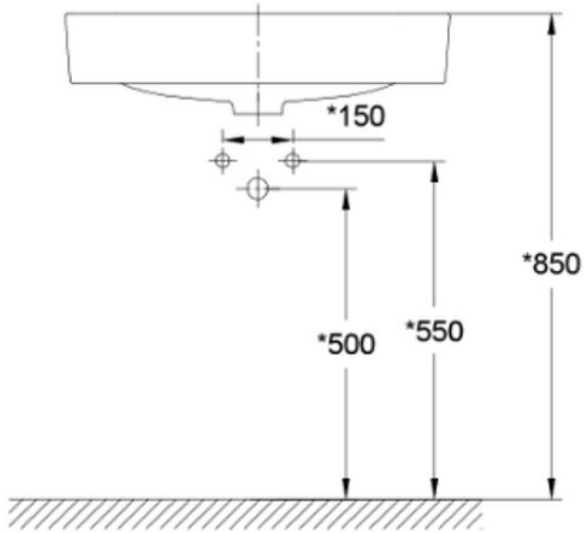

CCAS0628-0000410F0

## Signature

## Signature 550mm Vessel

<b>Item</b>	Description	No
<b>Installations</b>	Type	Vessel
<b>Dimensions</b>	Product (mm)	550 x 400 x 100
<b>Material &amp; Color</b>	Material	Vitreous China
	Color	White
<b>Features</b>	Overflow Hole	Without
	Faucet Ledge	No
<b>Components</b>	Included	No
<b>Shipping</b>	Net Weight (kg)	13
	Gross Weight (kg)	13
	Product Weight (kg)	11
	Dimensions (mm)	551 x 399 x 144