

Tolerance, Unless Otherwise Stated, Is				
Above	0.5 to and including	6	±0.1	
Excess	6 to and including	30	±0.2	
Excess	30 to and including	120	±0.3	
Excess	120 to and including	315	±0.5	
Excess	315 to and including	1000	±0.8	
Excess	1000 to and including	2000	±1.2	

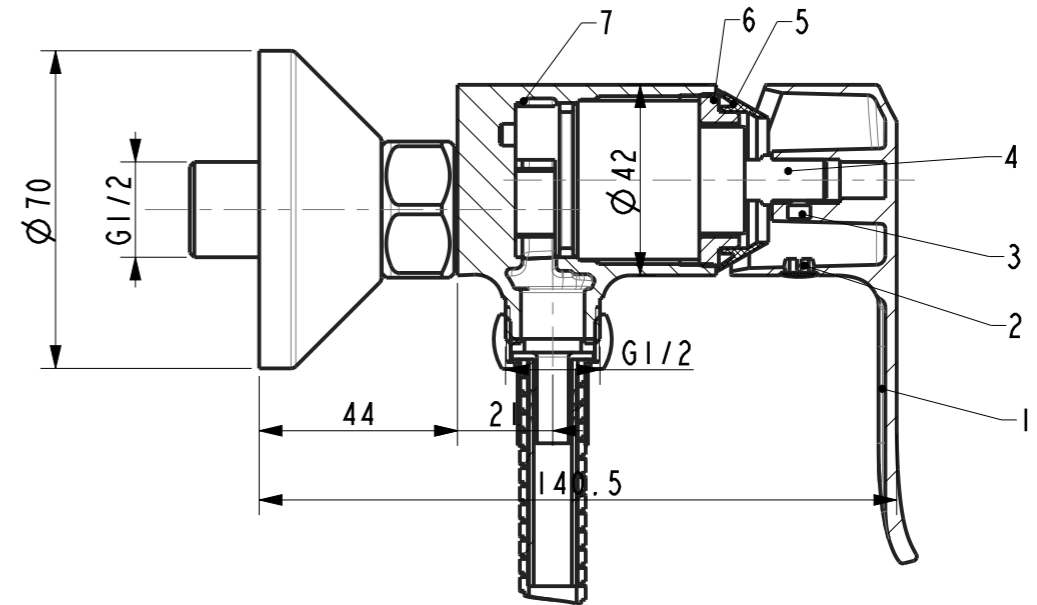

Technical requirements:

1. Cartridge tightening torque is 8 ~ 10 N.M, and the other torque is implemented according to the "W109.1520 assembly torque specification".
2. The finished product should meet GB18145 and W110.0504 final inspection standard.

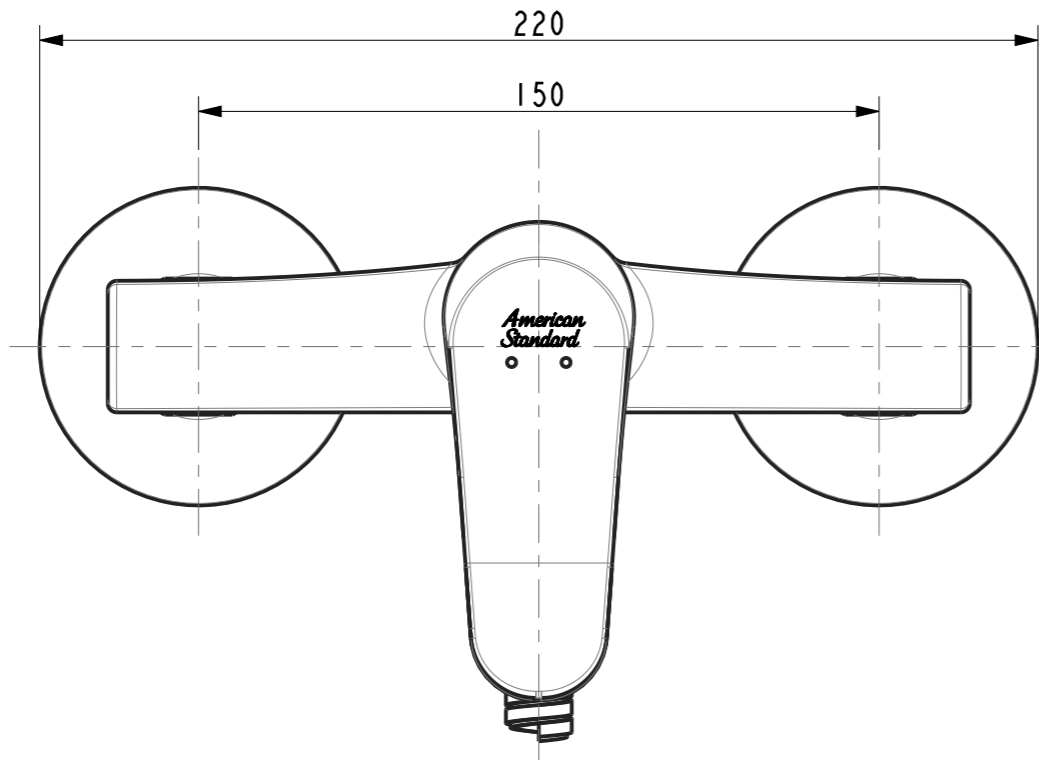
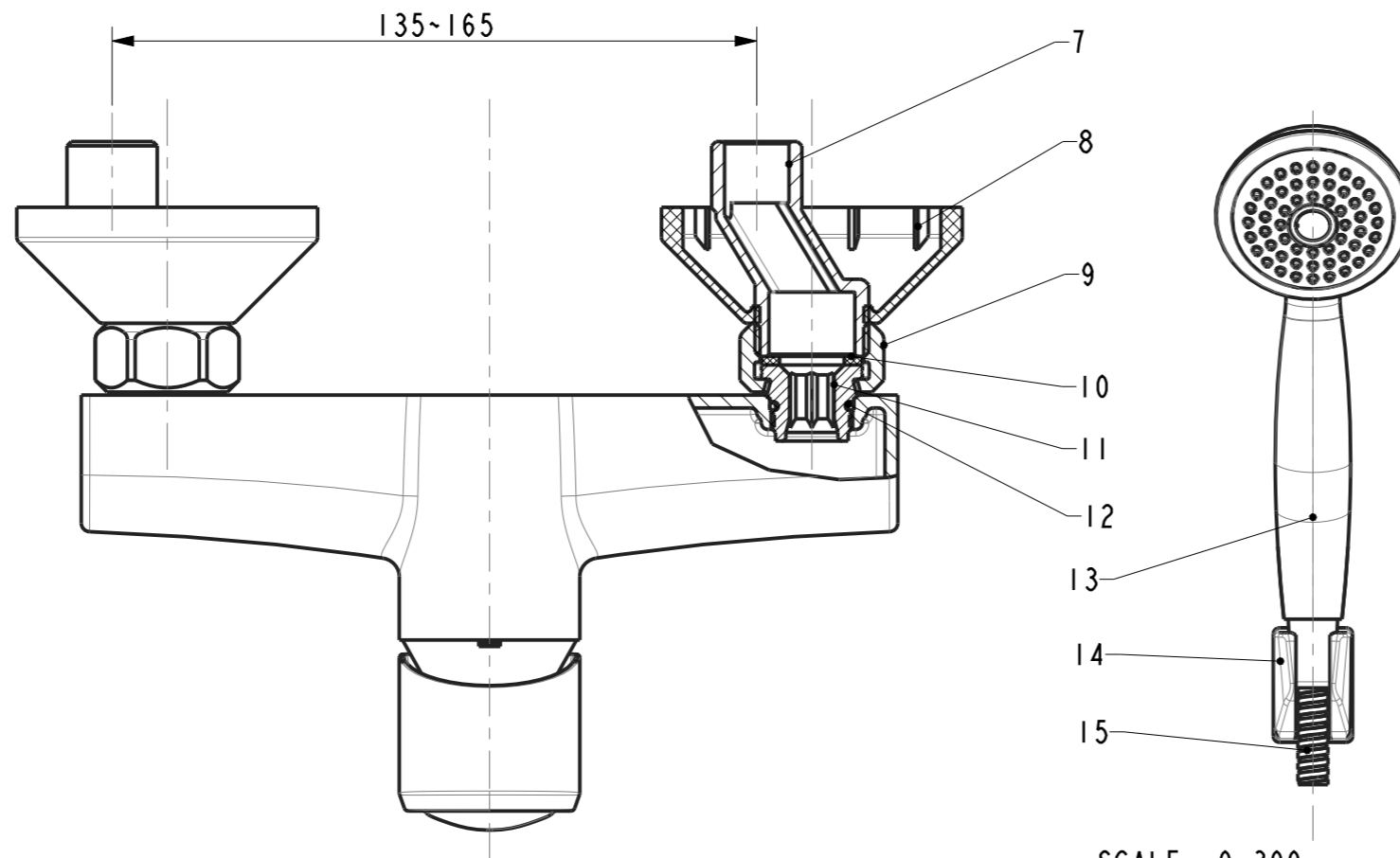

SCALE 0.300

16	FF1-CN521T00000025	Shower Hose	Assembly	1	
15	FF1-CN521H00000055	Shower holder	Assembly	1	
14	FF1-CN521H00001850	Hand Shower	Assembly	1	
13	FF1-CN521G00000112	O ring 15.6*1.78	NBR70	2	
12	FF1-CN521W00000048	THREADED NIPPLE	HPb59-1	2	
11	FF1-CN521G000000341	Washer Ø24*Ø15*2	Fiber	2	
10	FF1-CN521N000000291	Nut G3/4	HPb59-1	2	
9	FF1-CN521F000000094	Escutcheon	ABS	2	
8	FF1-CN521J000000242	S Connector (G1/2 to G3/4)	SUS304	2	
7	FFZZ0712-70150BDPL	Body	GkMs60Fk	1	
6	FF1-CN521N000000091	Cartridge Nut	HPb59-1	1	
5	FF1-CN521F000000042	Cartridge Cover	ABS	1	
4	FF1-CN521C00001399	Cartridge 35mm	Assembly	1	
3	FF1-CN521N000000899	Screw M5	SUS304	1	
2	FF1-CN521Z000000086	Handle Cover	ABS	1	
1	FF1-CN521L000000091	Handle	ZZnA14-1	1	
No.	Part Code	Description	Material	Qty	Remark

DESIGNED		TITLE
CHECKED		REF
APPROVED		Neo Modern EX Shower Only mixer
SCALE	MATERIAL	WEIGHT
3:5	Assembly	
DWG NO.		<b>American Standard</b>
FFAS0712-701500BF0		

REV	DESCRIPTION	DATE	NAME