

FFASS506-000610BT0

Genie

Genie Hand Shower W/Hose&Holder (MB)-TH

STYLE SEGMENT

- Modern

KEY SPECIFICATIONS

- Product Description: Genie Hand Shower W/Hose & Holder (Matt Black)
- Hand Shower Face Diameter: 100
- Finish: Powder Coating
- Material: Plastic
- Flow Rate: 5.8 @1 bar
- Additional Components Included: shower hose and shower holder
- Hose Included: Yes



SHIPPING WEIGHT

- Net Weight: Contact us for more information
- Gross Weight: Contact us for more information

KEY TECHNOLOGIES AND FEATURES

HYGIENE

- Complies with American Standard Quality Standards

COMFORT

- Complies with American Standard Quality Standards

CONVENIENCE

- Complies with American Standard Quality Standards

DURABILITY

- Complies with American Standard Quality Standards

SUSTAINABILITY

- Water-Saving

SAFETY

- Complies with American Standard Quality Standards

OTHERS

- NIL

STANDARDS AND CERTIFICATIONS

- TIS 2067-2552

FFASS506-000610BT0

Genie

Genie Hand Shower W/Hose&Holder (MB)-TH

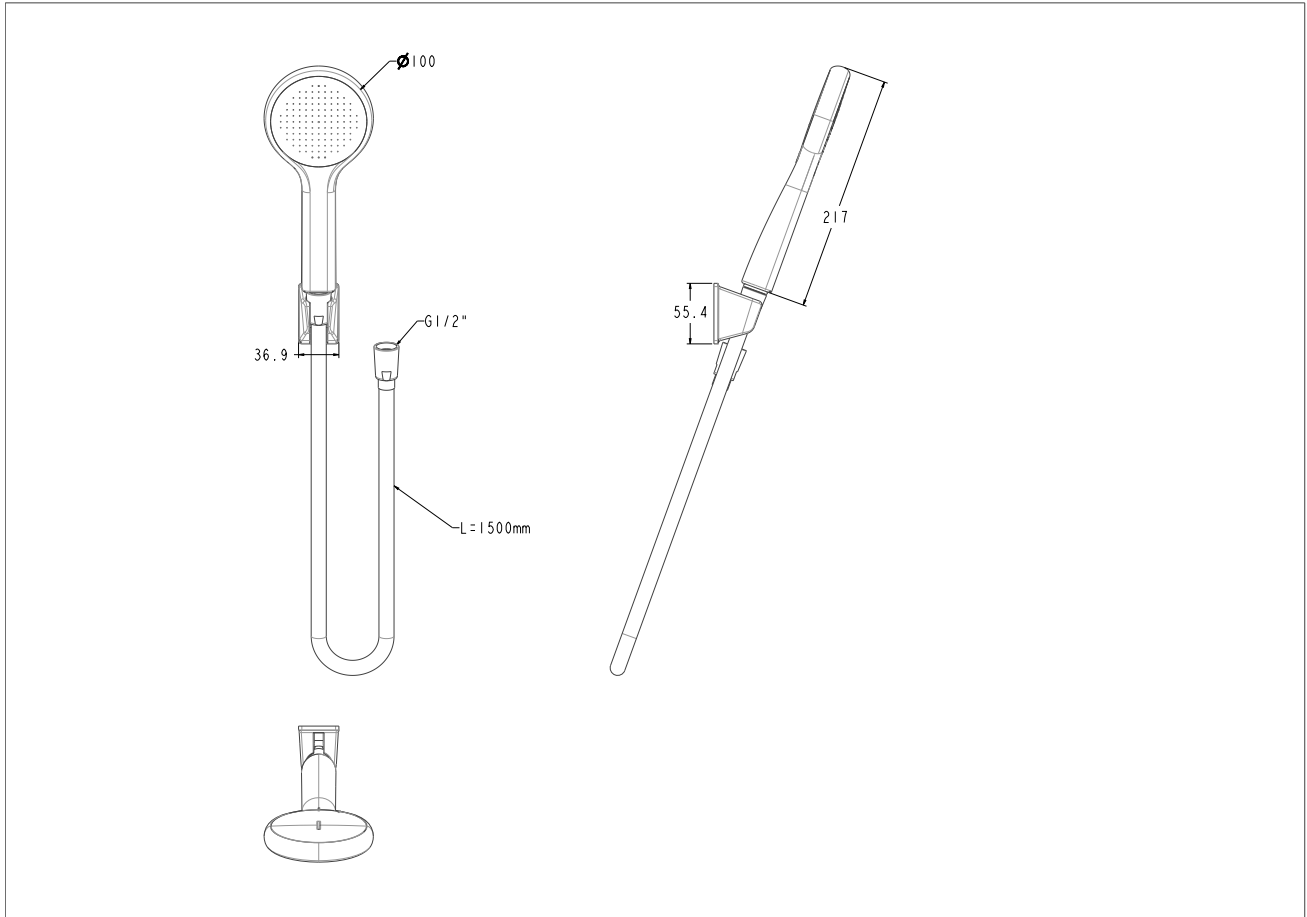

FFASS506-000610BT0

Genie

Genie Hand Shower W/Hose&Holder (MB)-TH

Product	Description	Genie Hand ShowerW/Hose & Holder (Matt Black)
	Weight (kg)	0.4
	Dimensions (mm)	228 x 100 x 29
	Finish	Powder Coating
	Material	Plastic
	Flow Rate	5.8 @1 bar
Hand Shower	Face Diameter (mm)	100
Components	Additional Components Included	shower hose and shower holder
	Hose Included	Yes
	Includes Trim Kit	Yes
	Include Shower Accessories	Yes