

Tolerance, Unless Otherwise Stated, Is			
Above	0.5 to and including	6	±0.1
Excess	6 to and including	30	±0.2
Excess	30 to and including	120	±0.3
Excess	120 to and including	315	±0.5
Excess	315 to and including	1000	±0.8
Excess	1000 to and including	2000	±1.2

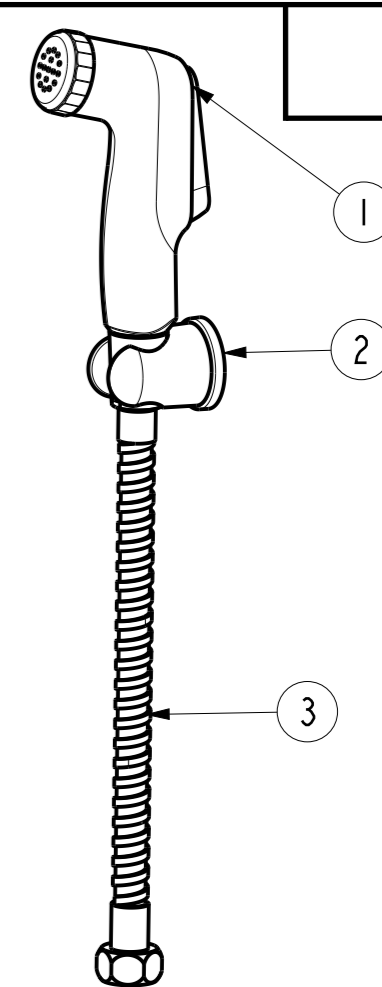
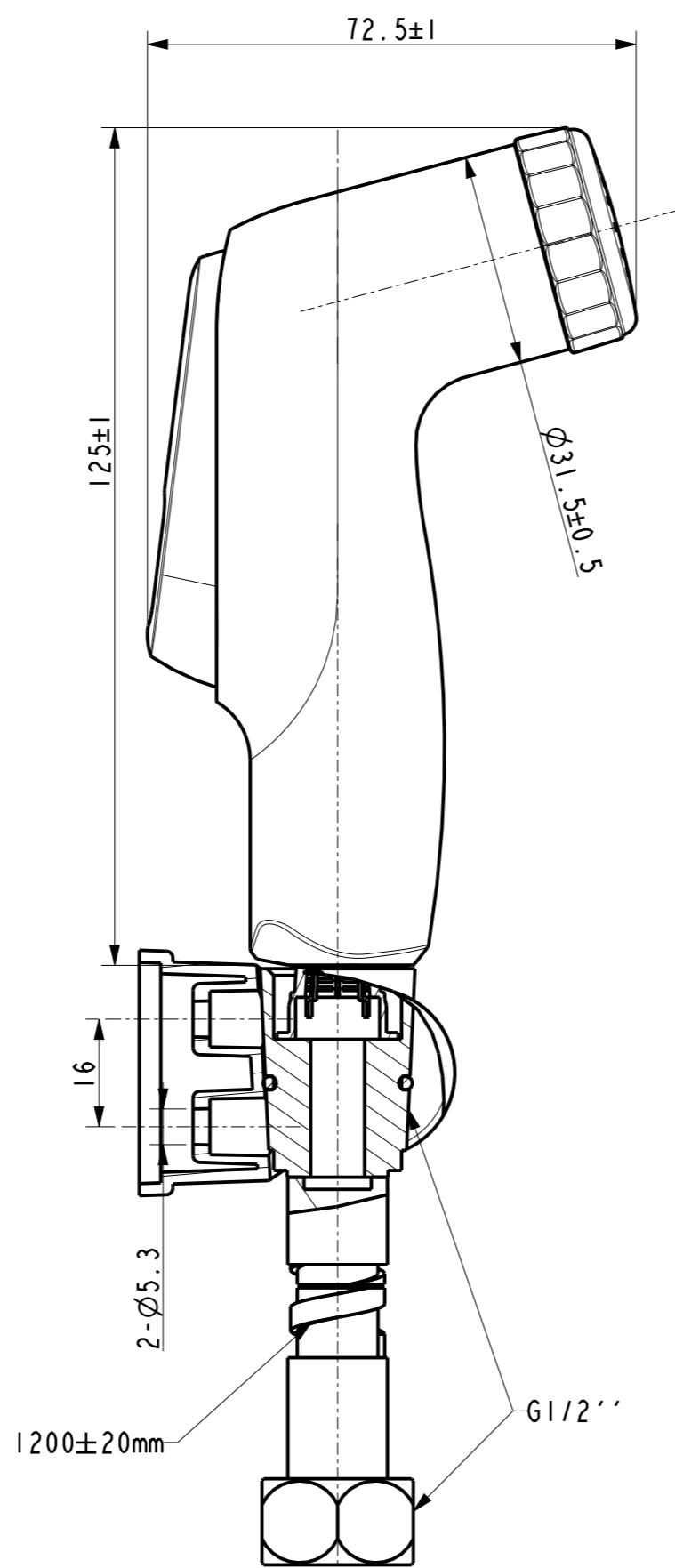
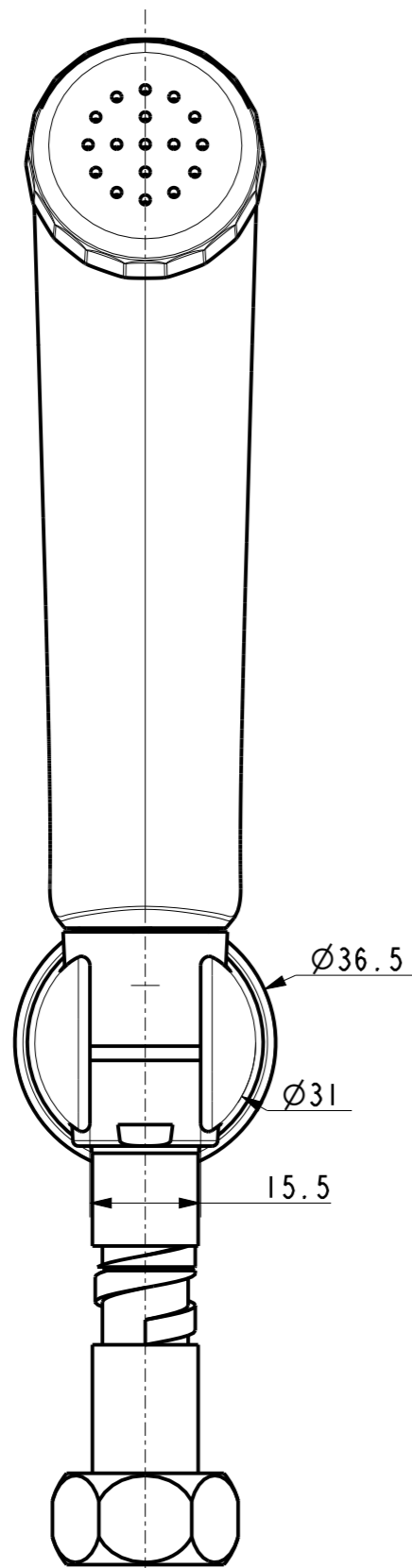

技术要求:

1. 零件外观清洁, 不得有尖锐棱角、碰划伤、披锋、锈斑等缺陷
 2. 耐腐蚀性AASS, 24H, 10级。
 3. 螺纹表面不应有断牙、凹痕等明显缺陷、外接螺纹G1/2"须符合通规通、止规止。
 4. 流量: 在动水压1bar下, 流量≤ 5L/min。
 5. 密封性能(喷枪组件)
 - 5.1 在17.5bar静压下关闭喷枪保持60s不渗漏。
 - 5.2 在5bar动压下切换按钮开关不渗漏。
 - 5.3 在0.5bar动压下切换按钮开关不渗漏。
 6. 寿命(喷枪组件), 达到10万次。
- 试验过程中零部件不应出现断裂、卡阻和渗漏现象。
试验完成后喷枪组件的密封性能应符合5的规定。
8. 按钮操作力≤ 35N。

No.	Part No.	Part name	Material	QTY	Remark
3		Shower hose	SUS304	1	Chrome
2	F65604-WTADY	Shower holder	ABS	1	Chrome
1		Spray	Assembly	1	White

DESIGNED	李爽	TITLE
CHECKED		REF
APPROVED		CURVE HYGENIC SPRAY-CHROME
SCALE	MATERIAL	WEIGHT
1:1	Assembly	DWG NO.
		F65604-CHADY

**American
Standard**

REV	DESCRIPTION	DATE	NAME