

Tolerance, Unless Otherwise Stated, Is			
Above 0.5 to and including 6	6		±0.1
Excess 6 to and including 30	30		±0.2
Excess 30 to and including 120	120		±0.3
Excess 120 to and including 315	315		±0.5
Excess 315 to and including 1000	1000		±0.8
Excess 1000 to and including 2000	2000		±1.2

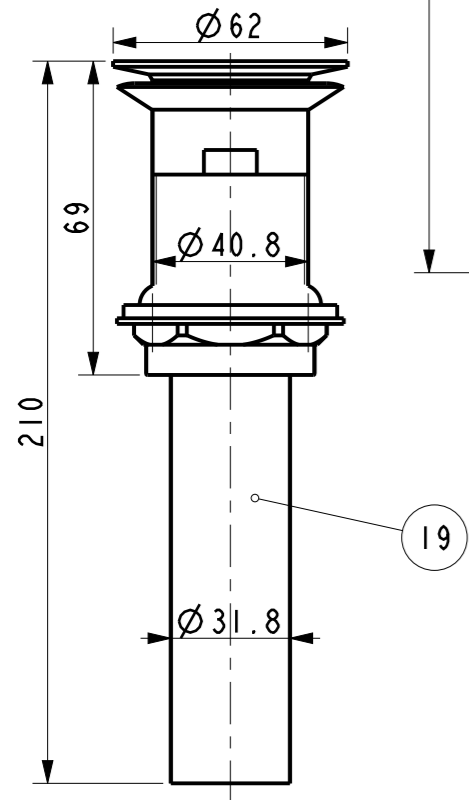
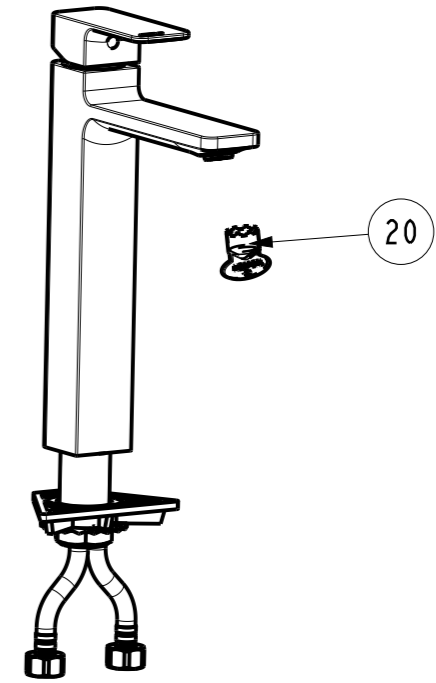
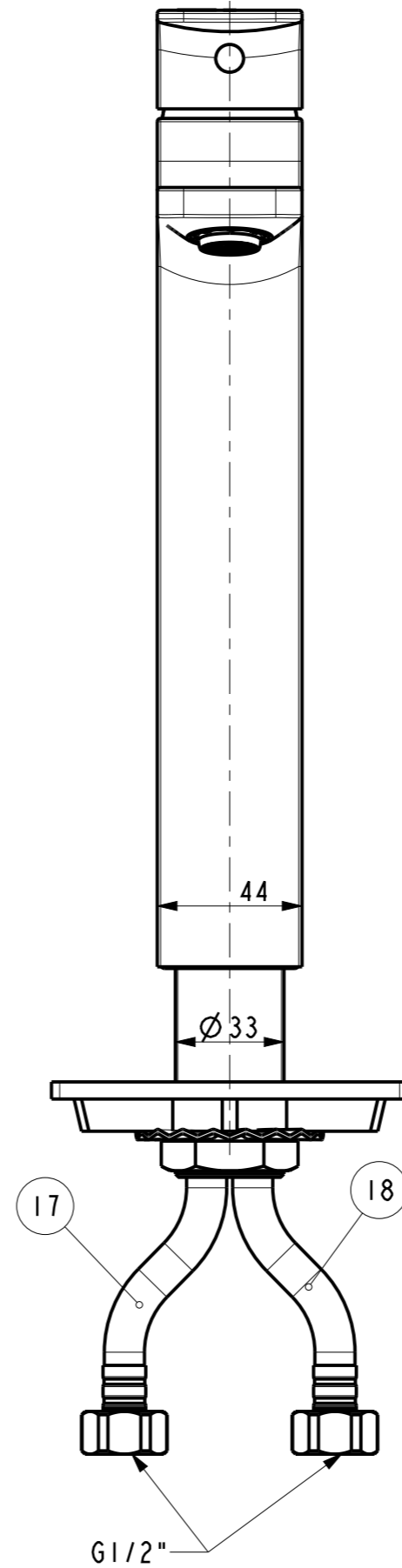
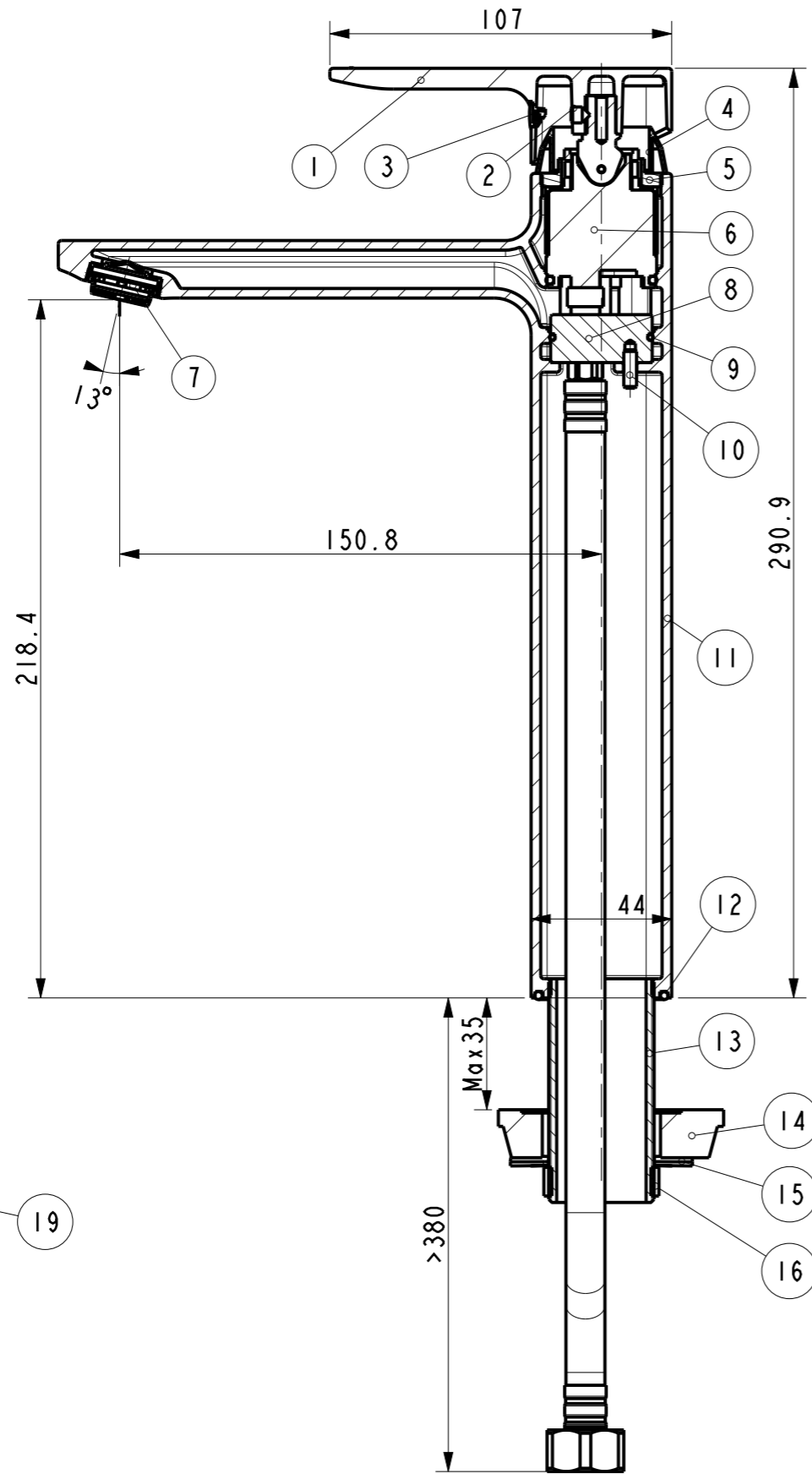

20	FF1-CN521A00000097	Aerator Key	1	PA66-GF30	
19	FF1-CN521X00000066	Press-Action Pop-up	1	Assembly	
18	FF1-CN521T00000019	Flexible Hose	1	Assembly	
17	FF1-CN521T00000020	Flexible Hose	1	Assembly	
16	FF1-CN521N00000296	Nut M33*1.5 n=9 N	1	Hpb59-1	
15	FF1-CN521J00000500	Washer	1	SUS 304	
14	FF1-CN521Z00000062	Plate	1	POM	
13	FF1-CN521J00000271	Lock Teeth (M33*1.5)	1	Hpb59-1	
12	FF1-CN521G00000159	O-Ring 37*2.5	1	NBR	
11	FFZZ1302-10150BDPL	Body	1	GkMs60Fk	Chrome
10	FF1-CN521N00000176	Bolt M4*15	1	SUS 304	
9	FF1-CN521G00000247	O-ring 26.70*1.78	1	NBR	
8	FF1-CN521J00000056	Maifold	1	Hpb59-1	
7	FF1-CN521A00000102	Aerator (2.2gpm)	1	Assembly	
6	FF1-CN521C00000057	35#ECO Cartridge	1	Assembly	
5	FF1-CN521N00000091	Lock Nut	1	Hpb59-1	
4	FF1-CN521F0004050P	Cartridge Cover	1	ABS	Chrome
3	FF1-CN521Z00004950	Plug	1	ABS	
2	FF1-CN521N00000228	M5*6	1	SUS 304	
1	FF1-CN521L00000191	Handle	1	ZZnA14-1	Chrome
NO.	PART NO.	PART NAME	QTY	MATERIAL	FINISH

DESIGNED			TITLE		
CHECKED			REF		
APPROVED			Acacia Evolution Extended Basin Mixer with Pop-up Drain		
SCALE	MATERIAL	WEIGHT	DWG NO.		
1:2	Assembly		FFAS1302-101500BC0		

American Standard

REV	DESCRIPTION	DATE	NAME