

Tolerance, Unless Otherwise Stated, Is				
Above	0.5 to and including	6	±0.1	
Excess	6 to and including	30	±0.2	
Excess	30 to and including	120	±0.3	
Excess	120 to and including	315	±0.5	
Excess	315 to and including	1000	±0.8	
Excess	1000 to and including	2000	±1.2	

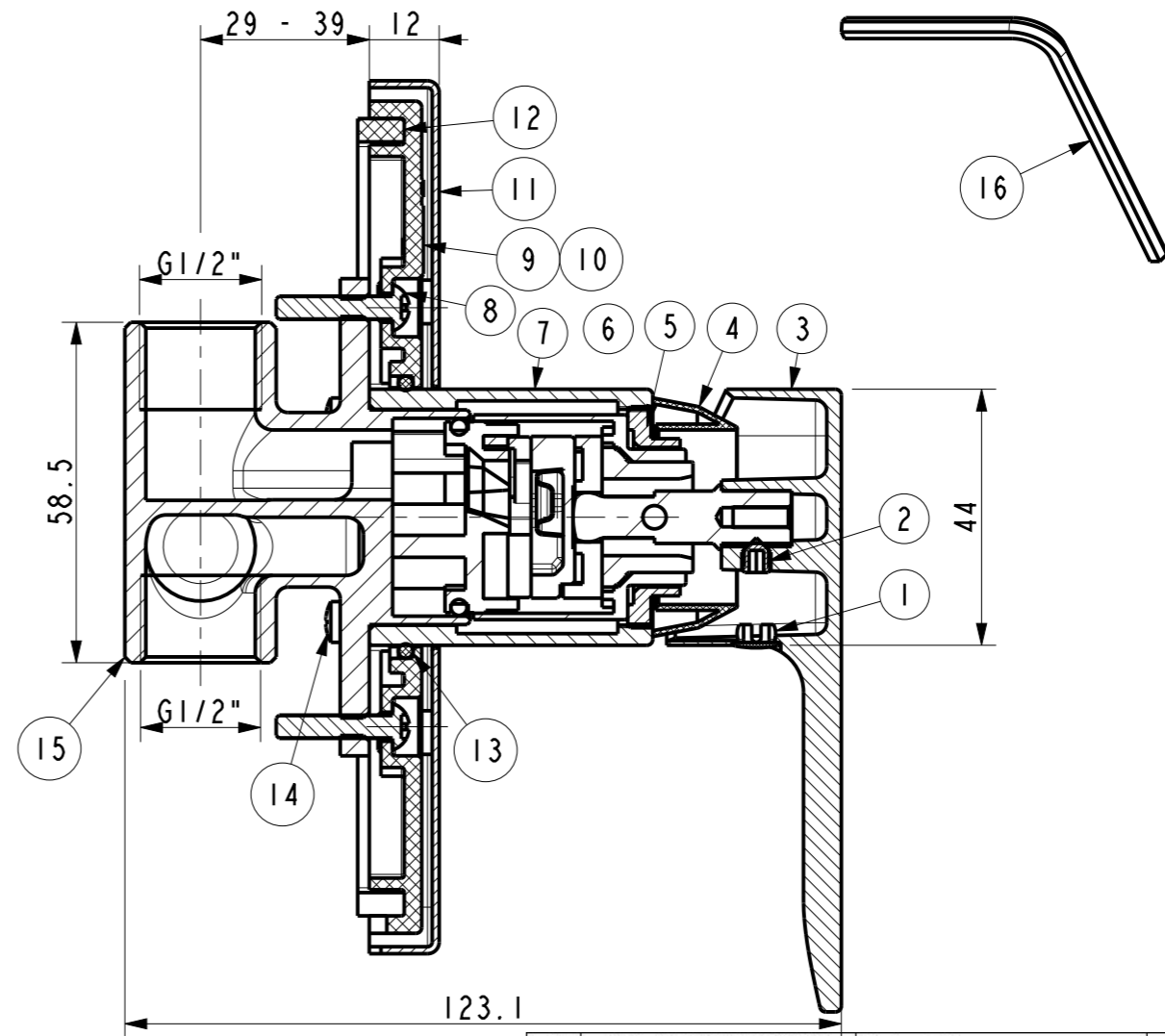

SECTION A-A

17	FF1-CN521Z00000212	Protect Cover	1	PP	
16	FF1-CN521Z00000254	In-Hex Wrench	1	Q235	
15	FF1-CN521B00000019	Body	1	GkMs60Fk	
14	FF1-CN521N00000169	The bolt M4 L=9	6	SUS 304	
13	FF1-CN521G00000364	Sealing Ring	1	NBR	
12	FF1-CN521K00000034	Foam Washer	1	E.V.A	
11	FF1-CN521F00000280	Escutcheon	1	H62+HPb59-1	Cr
10	FF1-CN521G00000291	O-Ring(7X2)	4	NBR	
9	FF1-CN521F00000278	Fixing Plate	1	ABS	
8	FF1-CN521N00000268	Screw (M4X20)	2	SUS 304	
7	FF1-CN521J00000554	Brass Bushing	1	HPb59-1	Cr
6	FF1-CN521C00000041	Cartridge(N35HW)	1	Assembly	
5	FF1-CN521N00000096	Lock Nut	1	HPb59-1	
4	FF1-CN521F00000034	Cartridge Cover	1	ABS	Cr
3	FF1-CN521L00000199	Handle	1	ZZnAl4-1	Cr
2	FF1-CN521N00000228	Screw M5*6	1	SUS 304	
1	FF1-CN521Z00004950	Plug for handle	1	ABS	Cr
NO.	PART NO.	PART NAME	QTY	MATERIAL	FINISH

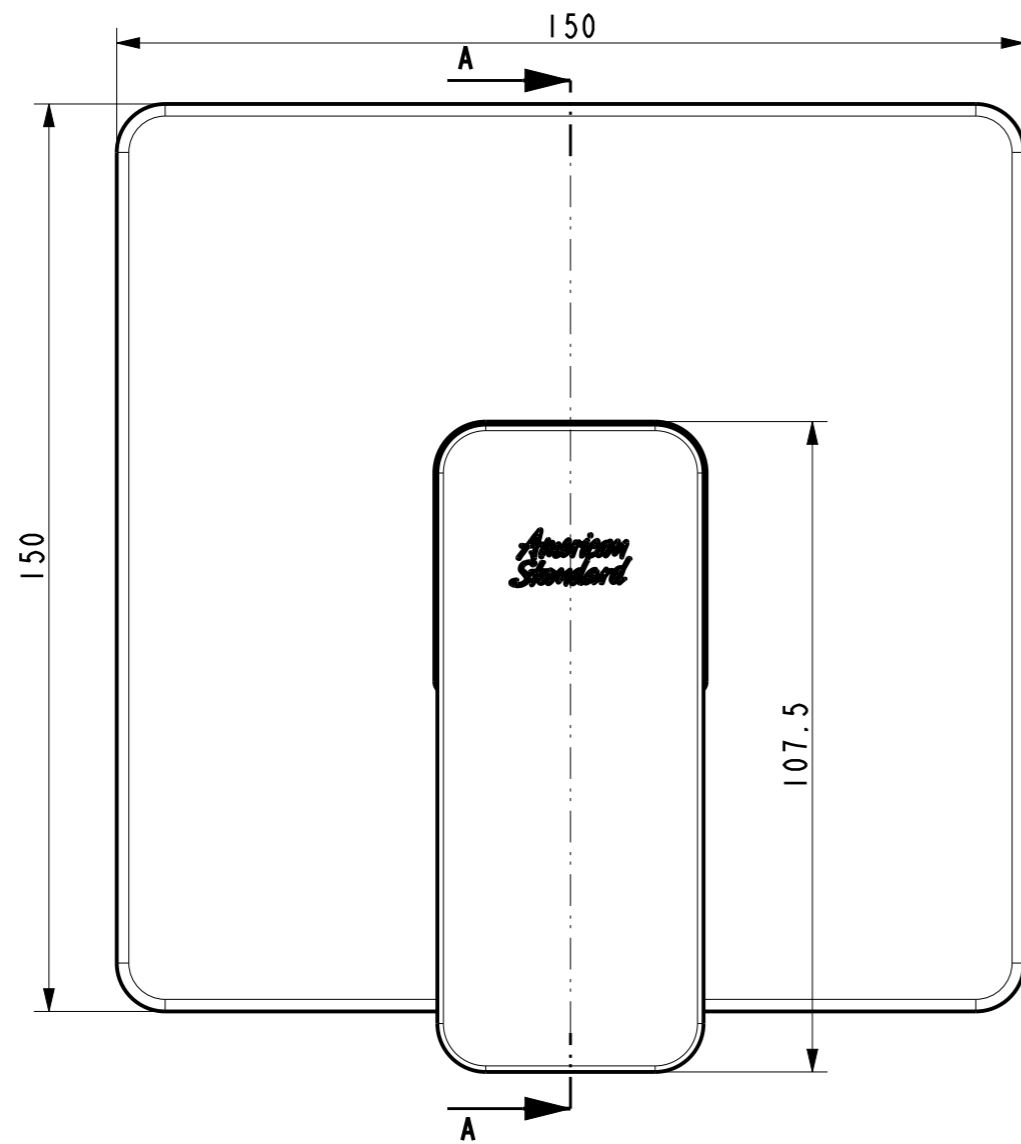
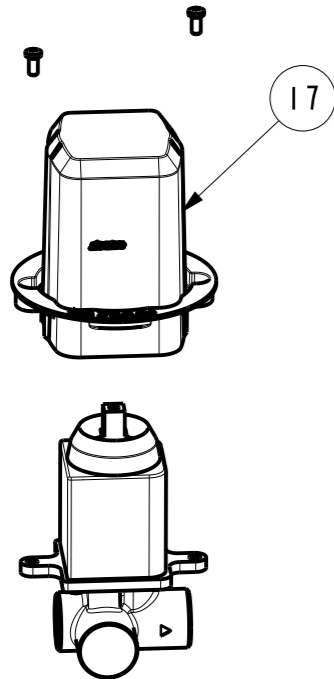

SCALE 0.300

REV	DESCRIPTION	DATE	NAME

DESIGNED			TITLE
CHECKED			REF
APPROVED			Acacia E Concealed Shower Mono
SCALE	MATERIAL	WEIGHT	DWG NO.
4:5	Assembly		FFAS1336-709500BF0

American Standard