

Tolerance, Unless Otherwise Stated, Is			
Above	0.5 to and including	6	±0.1
Excess	6 to and including	30	±0.2
Excess	30 to and including	120	±0.3
Excess	120 to and including	315	±0.5
Excess	315 to and including	1000	±0.8
Excess	1000 to and including	2000	±1.2

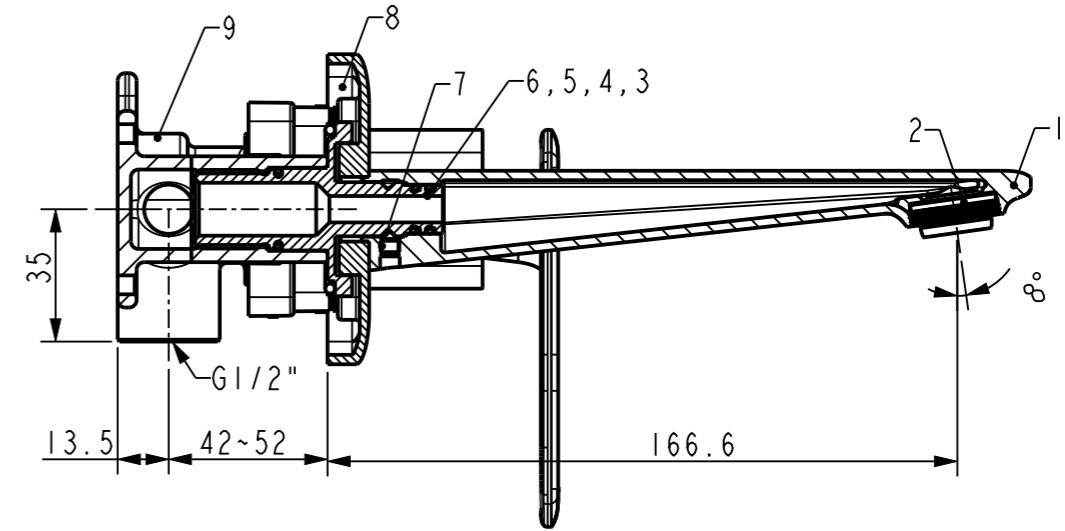

SECTION B-B

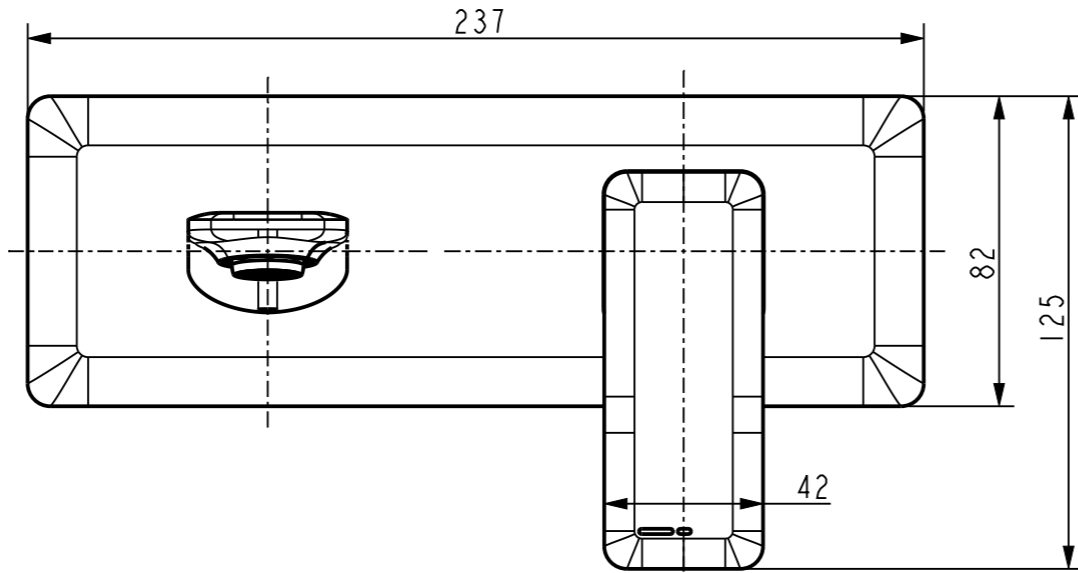
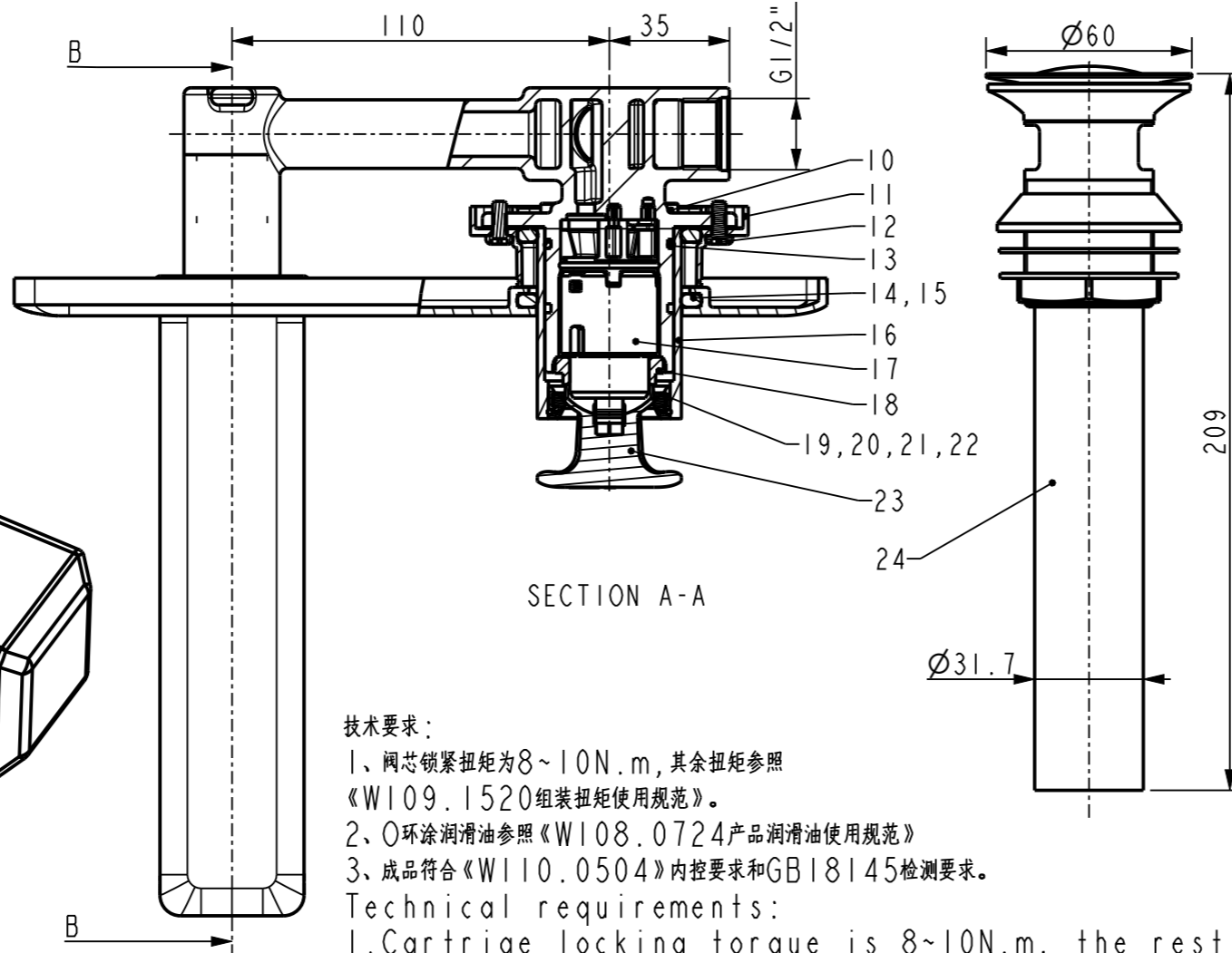
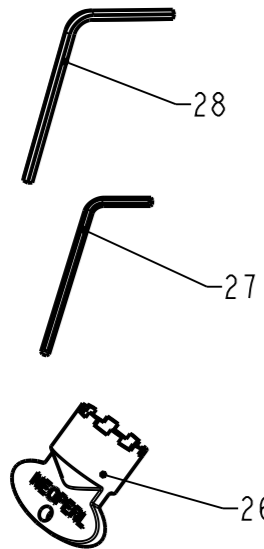

SECTION A-A

技术要求:

- 1、阀芯锁紧扭矩为8~10N.m, 其余扭矩参照《W109.1520组装扭矩使用规范》。
- 2、O环涂润滑油参照《W108.0724产品润滑油使用规范》
- 3、成品符合《W110.0504》内控要求和GB18145检测要求。

Technical requirements:

1. Cartridge locking torque is 8~10N.m, the rest of the torque refer to <W109.1520>.
2. O ring lubricating refer to <W108.0724>
3. The finished product meets the W110.0504 final inspection standard and GB18145.

No.	Part Code	Part Des. (EN)	Material	Qty.	Remark
28	FF1-CN521Z00000254	In-Hex Wrench for H01 Mixer	Q235-A	1	
27	FF1-CN521Z00000253	1582362699\Hex Wrench(W.A.F 3)	Q235-A	1	
26	FF1-CN521A00000097	1582364399\M24X1 SLIM Aerator Key	PA66	1	
25	FF1-CN521Z00000310	1585969799\Plug for New Mass In-wall Lav	PA	1	
24	FF1-CN521X0019750B	PA Brass Press Action Pop-up Drain	Component	1	Chrome Plated
23	4253100000	Handle for Acacia SS Concealed Basin Mixer	ZZnAl4-1	1	Chrome Plated
22	4253969990	Seal Ring for Acacia SS Basin Mixer	TPE	1	
21	4277669990	Screw M4x3-130°	SUS304	1	
20	FF1-CN521G0006399R	O Ring Ø28*1.5	NBR70	1	
19	4254150200	Cover for Acacia SS Basin Mixer	ABS	1	JMW-1
18	4214119990	G28 Cartridge nut (M33x1.5)	HPb59-1	1	
17	FF1-CN521C0002399P	G28 cartridge W/ distributor(408554840)	Component	1	
16	4254140000	Bushing for AcaciaSS WM Basin Mixer	HPb59-1	1	Chrome Plated
15	4254259990	ORing for AcaciaSS WM Basin Mixer	NBR70	2	
14	4254269990	Washer for AcaciaSS WM Basin Mixer	SUS304	1	
13	FF1-CN521G00000166	1581222499\O-Ring(33*2)	NBR70	1	
12	FF1-CN521N00000194	Screw M4x10	SUS304	4	
11	FF1-CN521Z0012399P	Protective Sleeve	PP	1	
10	G-09452031	CHEESE HEAD SCREW DIN 6912-A M4x8-1430	SUS304	4	
9	4214099990	Body for Loven Concealed Basin Mixer	GkMs60Fk	1	
8	4254290000	Escutcheon for AcaciaSS WM Basin Mixer	ZZnAl4-1	1	Chrome Plated
7	FF1-CN521N00000228	In-Hex Screw for Celia LeverM5*6	SUS304	1	
6	FF1-CN521G00000361	1591276099\O-RING-39.34*2.62.N	NBR70	1	
5	FF1-CN521G00000251	158A912621\O Ring Ø17*2	NBR70	1	
4	FF1-CN521G00000136	O-Ring 9*2	NBR70	2	
3	4254139990	Adapter for ACACIASS WM Basin Mixer	SUS304	1	
2	FF1-CN521A0008299P	M24X1 SLIM Air(ECO)Joy2.1.2GPM)	Component	1	
1	4254110000	Spout for Acacia SS Concealed Basin Mixer	GkMs60Fk	1	Chrome Plated

DESIGNED	CK PAN	2025.3.1	TITLE
CHECKED	Aaron Wang	2025.03.01	Acacia SS Wall-Mounted Basin Mixer_APAC
APPROVED	Frank	2025.3.1	REF 新阿卡西亚薄舒丽入墙碗盆龙头-镀铬_亚太
SCALE	MATERIAL	WEIGHT	DWG NO.
1:2	Assembly		1124170000



REV	DESCRIPTION	DATE	NAME