

Care & Maintenance

**! Please don't put heavy things on top to ensure the enduring safety of the hanger.
(the enduring limit should be within 5 kgs)**

Warm Tips

Please pay attention to below when you clean the metal coating.

1. Do not use any acid cleanser.
2. Do not use any abrasive cleanser.
3. Do not use any abrasive tool such as emery cloth or metal wire.

Maintenance Instruction on Metal Coating

1. Rinse the surface faucet with clean water first, then dry it with soft cotton cloth.
2. If there is some surface dirt and film which is difficult to clean, please use litmusless or alkaline cleanser to clean them (recommended PH value is 7-9). Then rinse it with clean water and dry it with soft cotton cloth.

* The user need to take the responsibility for any damage caused by improper maintenance and clean.

Acacia E



FFAS1381-908500BF0
(WF-1381.908.50)
Acacia E Robe Hook

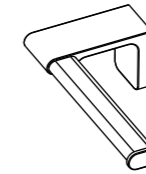

FFAS1387-908500BF0
(WF-1387.908.50)
Acacia E Tissue Holder

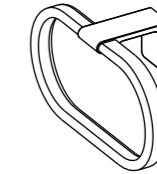

FFAS1390-908500BF0
(WF-1390.908.50)
Acacia E Towel Ring

American Standard

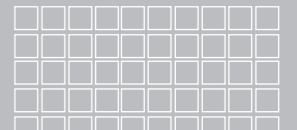

Installation &
Operation Instructions

**Thank you for selecting American-Standard - the benchmark of fine quality for over 100 years.
To ensure that your installation proceeds smoothly--please read these instructions carefully before you begin.**

* American Standard always keep raising and improving the product design and performance, and reserve the right to modify the dimension and specification. At this case, we will not inform you separately.

* This installation instruction sheet is for your reference only, the dimension and specification is subject to the actual products.

Pre-Installation Checks

All instruction procedures must comply in strict accordance with applicable local plumbing and building codes

*** Before assembling, please make sure the drilled position in the assembling part is safe.**

*** Check installation distances in the Dimension diagram to ensure correct installation.**

Mark: Please hold the body during assembling to avoid damage on the product.

Recommended Tools and Materials



Tape Measure



Sinker

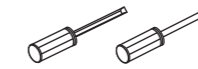

Screwdriver

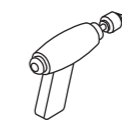

Drill

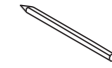

Pencil

Dimension

Unit: mm

FFAS1381-908500BF0

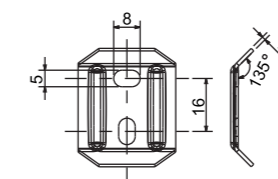
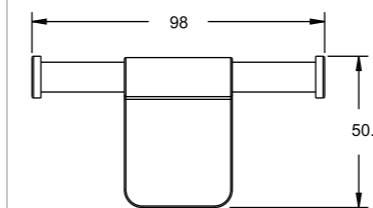

(The base mounting holes)

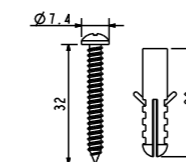

FFAS1387-908500BF0

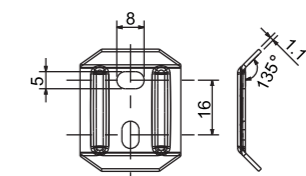
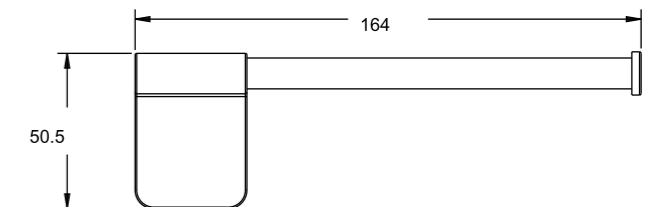

(The base mounting holes)

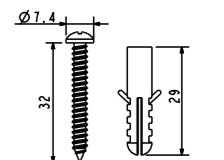

**Attention:
Please leave the manual with the customer
after installation is finished.**

Dimension

Unit: mm

FFAS1390-908500BF0

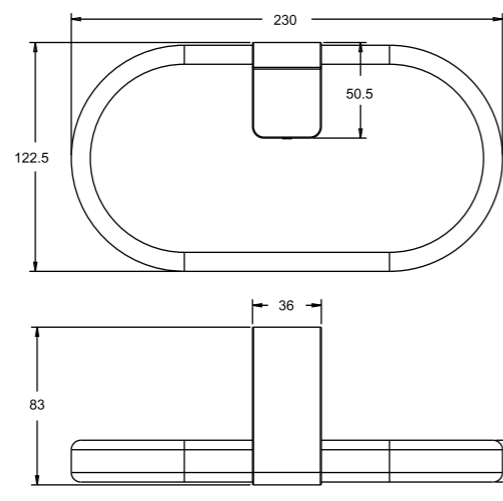
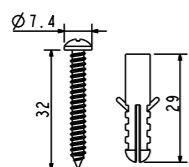
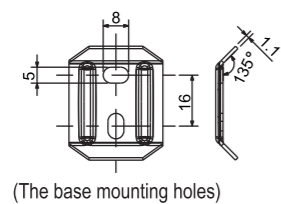

Parts List

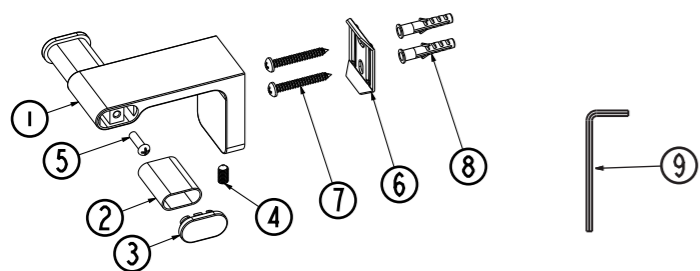

FFAS1381-908500BF0

Parts List

No.	Parts Name	Q'ty
1	Body	1
2	Rod	2
3	Plug	2
4	Screw	1
5	Screw	2
6	Mounting Bracket	1
7	Screw	2
8	Anchor	2
9	In-hex Wrench (2.5mm)	1

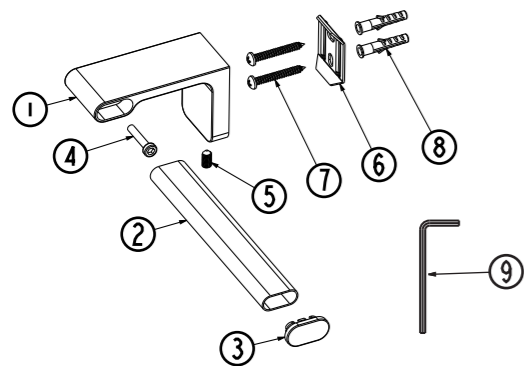

FFAS1387-908500BF0

Parts List

No.	Parts Name	Q'ty
1	Body	1
2	Rod	1
3	Plug	1
4	Screw	1
5	Screw (M5*10)	1
6	Mounting Bracket	1
7	Screw	2
8	Anchor	2
9	In-hex Wrench (2.5mm)	1

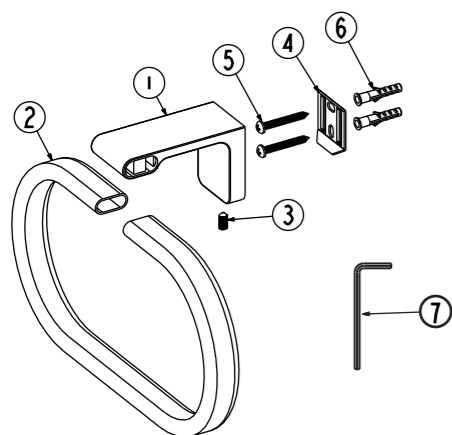

FFAS1390-908500BF0

Parts List

No.	Parts Name	Q'ty
1	Body	1
2	Ring	1
3	Screw (M5*10)	1
4	Mounting Bracket	1
5	Screw	2
6	Anchor	2
7	In-hex Wrench (2.5mm)	1

Installation

FFAS1381-908500BF0

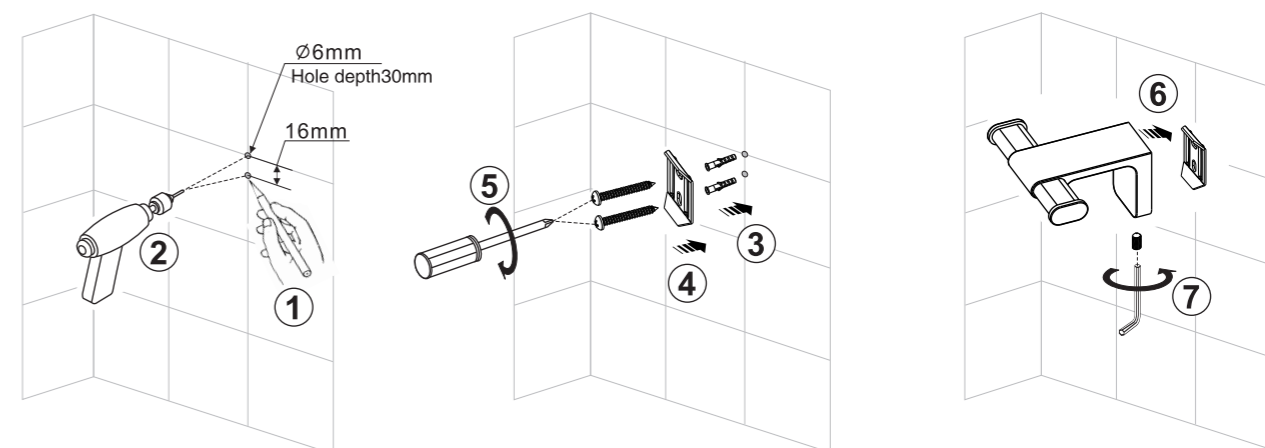

FFAS1387-908500BF0

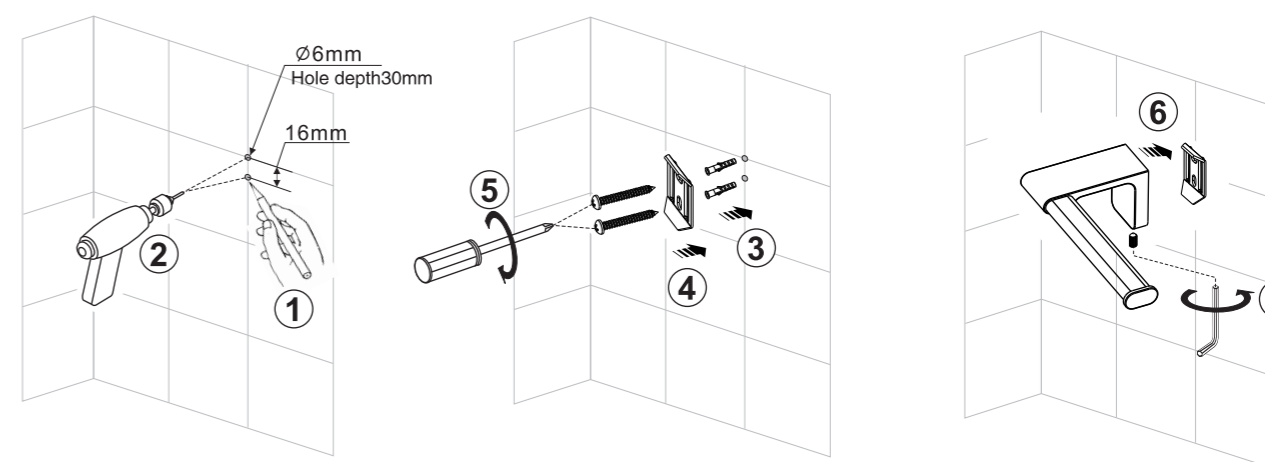

FFAS1390-908500BF0

