

A/O

Tolerance, Unless Otherwise Stated, Is			
Above 0.5 to and including 6	±0.1	6	±0.1
Excess 6 to and including 30	±0.2	30	±0.2
Excess 30 to and including 120	±0.3	120	±0.3
Excess 120 to and including 315	±0.5	315	±0.5
Excess 315 to and including 1000	±0.8	1000	±0.8
Excess 1000 to and including 2000	±1.2	2000	±1.2

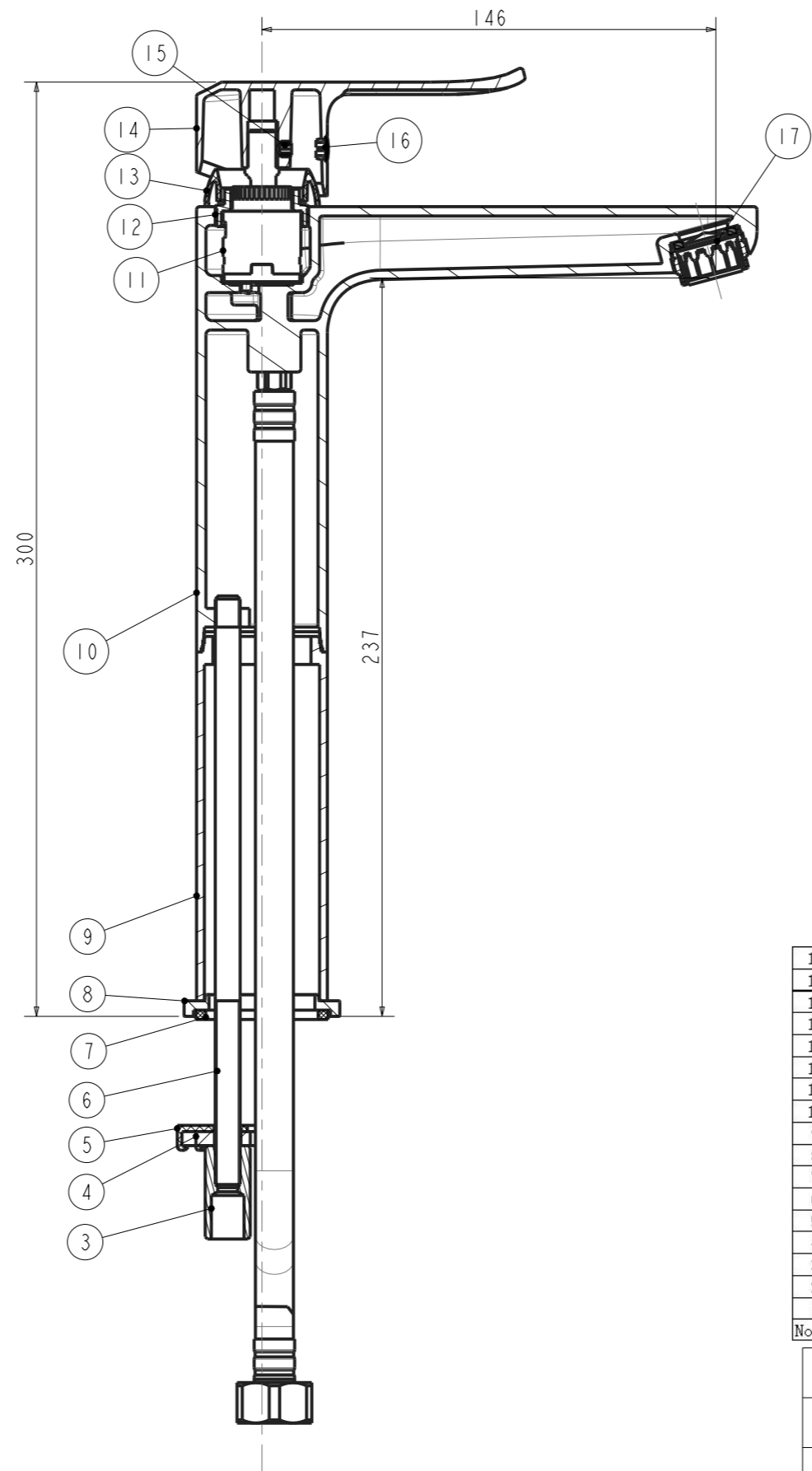
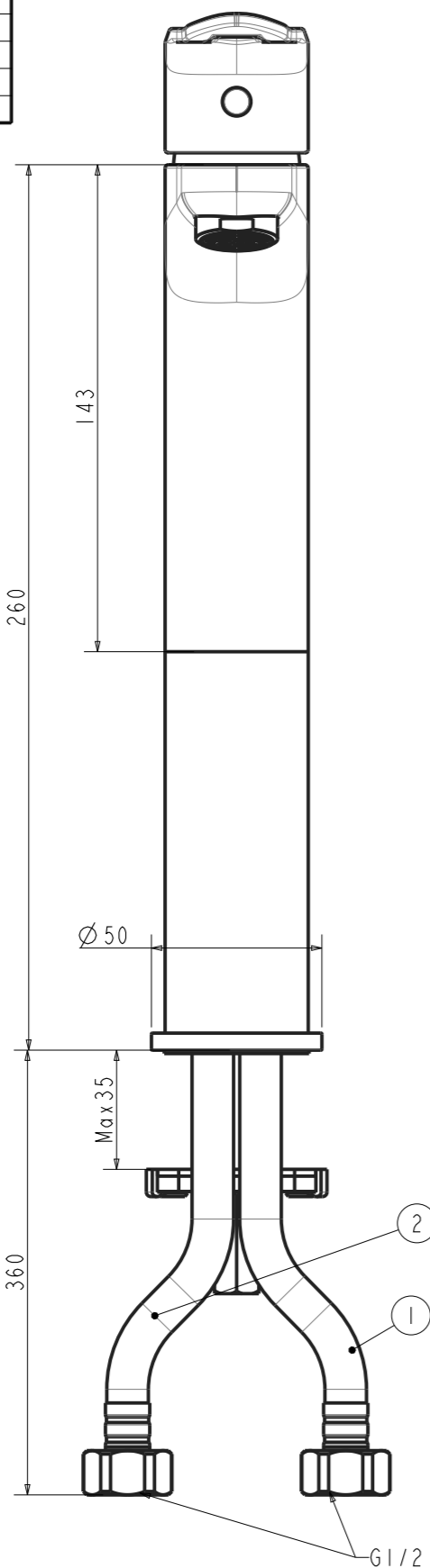

**Technical requirements:**

1. Cartridge tightening torque is 6 ~ 8 N.M, and the other torque is implemented according to the "WI09.1520 assembly torque specification".
2. O ring coated lubricating oil PMX200;
3. The finished product should meet GB18145 and WI10.0504 final inspection standard.

No.	Part Code	Description	Material	Qty	Remark
17	FF1-CN521A0001450B	Aerator	Assembly	1	
16	FF1-CN521Z00000086	1580970499\handle index cover	ABS	1	
15	FF1-CN521N00000228	158A917376\screw M5*6	SUS304	1	
14	FF1-CN521L00000091	158165235A\handle	ZZnAl4-1	1	
13	FF1-CN521F00000041	1580726950\cartridge cover	ABS	1	
12	FF1-CN521N00000045	1580491699\cartridge nut	Hpb59-1	1	
11	FF1-CN521C00000011	1585913299\Cartridge 25#	Assembly	1	
10	FFZZ0703-10150BDPL	1580047650\body	Gkms60Fk	1	
9	FF1-CN521J00000270	1581939950\extended tube	ZZnAl4-1	1	
8	FF1-CN521W00000030	1581445050\Bottom washer	Hpb59-1	1	
7	FF1-CN521G00000324	158K611029\Washer 42.5*36.1*3	NBR	1	
6	FF1-CN521Z00000191	1581721999\Bolt M8*190	SUS304	1	
5	FF1-CN521G00000238	Gasket	NBR	1	
4	FF1-CN521J00000432	158A923271\iron plate	Q235	1	
3	FF1-CN521N00000073	1580660999\fixation nut	Hpb59-1	1	
2	FF1-CN521T00000020	Flexible hose (Red) (600mm)	Assembly	1	
1	FF1-CN521T00000019	Flexible hose (Blue) (600mm)	Assembly	1	

DESIGNED	<i>[Signature]</i>	2019.11.27	TITLE
CHECKED	<i>[Signature]</i>	2019.11.27	REF
APPROVED	<i>[Signature]</i>	2019.11.27	Neo Modern Extended Basin Mixer w/o Pop-up Drain
SCALE	MATERIAL	WEIGHT	DWG NO.
1:2	Assembly		FFAS0703-109500BC0

REV	DESCRIPTION	DATE	NAME

**American Standard**