

Acacia Evolution

Extended Basin Mixer with Pop-Up

Drain

FFAS1302-101500BF0



FEATURES

- Modern design that can fit with any style of bathroom
- Eco-handle for saving energy (electric power)
- Click technology offers 2 different water flow rates 0~50% and 50~100% for easy volume control and water saving
- Ceramic disc valve for a life time use
- Strong brass construction
- Nickel and chromium plating for durable finish
- Adjustable water stream direction aerator
- With pop up drain
- Flow Rate @ 0.1 MPa: 5.4 L/Min

SPECIFICATIONS

- Extended Basin Mixer with Pop-Up Drain
- Single-Hole Installation
- Spout Reach: 151 mm
- Spout Height: 218 mm

FINISHES AVAILABILITY

- Chrome (- CP)

SHIPPING WEIGHT

- Net Weight: 2.7 KG
- Gross Weight: 2.95 KG

STANDARDS CRITERIA

- TIS 2067-2552
- GB 18145-2014

DIMENSIONAL DRAWING

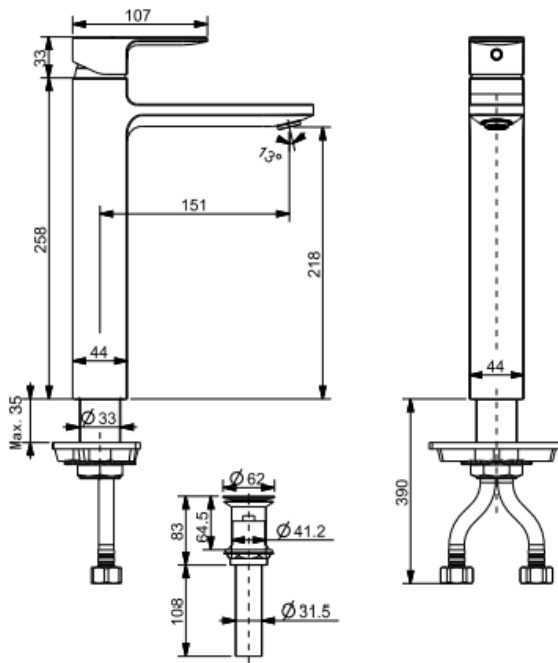

This document is the property of American Standard. It can neither be reproduced, nor communicated, without authorization.

American Standard reserves the right to change dimensions and specifications without notice; we assume no liability for the use of obsolete dimensions.