

Concept Square

Paper Holder

FFAS0487-908500BC0



FEATURES

- Modern design
- Zinc die casting base & pole
- Cast Brass rod
- SUS201 screw
- Black window box packaging

SPECIFICATIONS

- Paper Holder
- Chrome Finish

FINISHES AVAILABILITY

- Chrome (- CP)

SHIPPING WEIGHT

- Net Weight: 0.51 KG
- Gross Weight: 0.535 KG

STANDARDS CRITERIA

- QB/T 1560-2006

DIMENSIONAL DRAWING

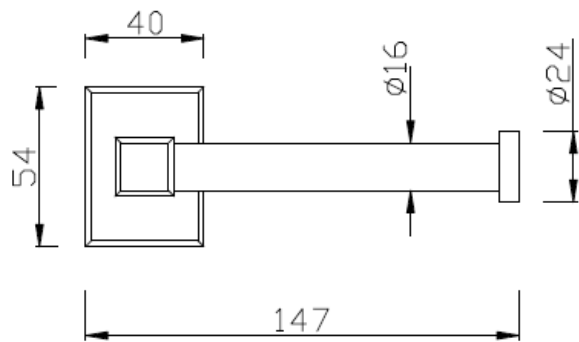
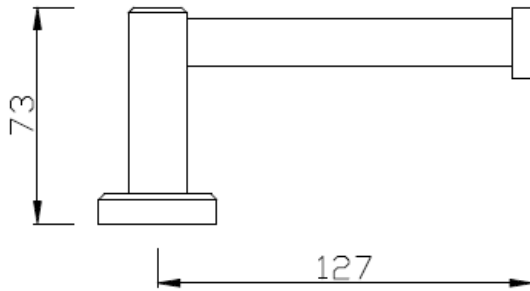

This document is the property of American Standard. It can neither be reproduced, nor communicated, without authorization.

American Standard reserves the right to change dimensions and specifications without notice; we assume no liability for the use of obsolete dimensions.