

FFASTS28-000DA0BT0

DuoSTiX

DuoSTiX™ Hygiene Spray\_DA0

**STYLE SEGMENT**

- Transitional

**KEY SPECIFICATIONS**

- Product Dimensions: 252x112x81
- Material: Plastic
- Color Availability: Contact us for more information
- Flow Rate: 5.06
- Additional Components Included: Contact us for more information
- Hose Included: Yes

**SHIPPING WEIGHT**

- Net Weight: Contact us for more information
- Gross Weight: Contact us for more information

**KEY TECHNOLOGIES AND FEATURES**

**HYGIENE**

- Complies with American Standard Quality Standards

**COMFORT**

- Complies with American Standard Quality Standards

**CONVENIENCE**

- Complies with American Standard Quality Standards

**DURABILITY**

- Complies with American Standard Quality Standards

**SUSTAINABILITY**

- Complies with American Standard Quality Standards

**SAFETY**

- Complies with American Standard Quality Standards

**OTHERS**

- NIL

**STANDARDS AND CERTIFICATIONS**

- GB/T 23447-2009



FFASTS28-000DA0BT0

DuoSTiX

DuoSTiX™ Hygiene Spray\_DA0

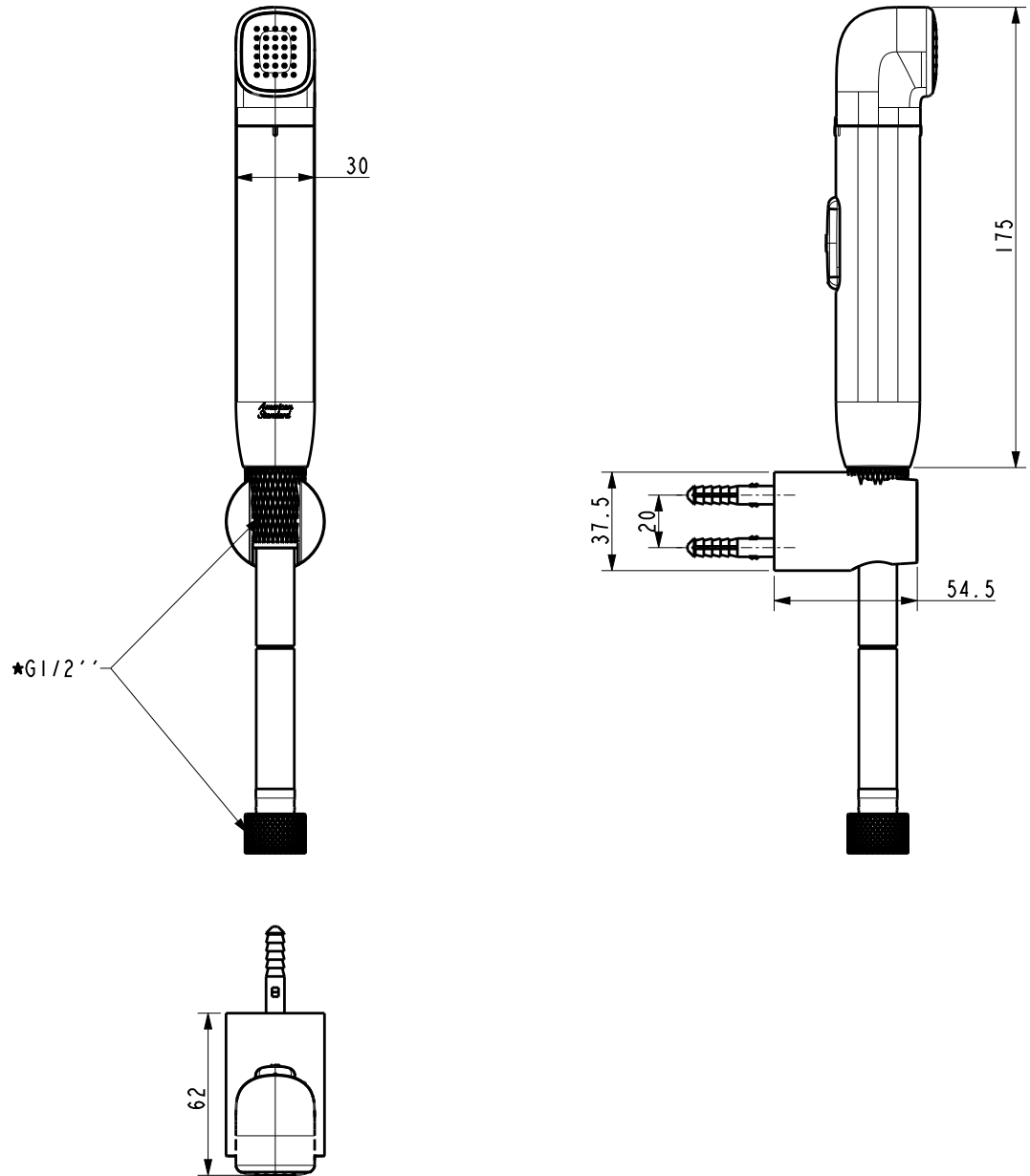

FFASTS28-000DA0BT0

DuoSTiX

DuoSTiX™ Hygiene Spray\_DA0

| Components | Description                    | Contact us for more information |
|------------|--------------------------------|---------------------------------|
|            | Weight (kg)                    | 0.44                            |
|            | Dimensions (mm)                | 252x112x81                      |
|            | Material                       | Plastic                         |
|            | Flow Rate                      | 5.06                            |
| Shipping   | Additional Components Included | Contact us for more information |
|            | Hose Included                  | Yes                             |