

Care & Maintenance

⚠ For safety reasons, please refrain from placing heavy items on top of the shelf. (weight limit no more than 5kg)

* To keep the product clean, please follow these simple care instructions:

- DO:
1. Wipe the product clean with a damp cloth.
 2. Dry the product with a soft cotton cloth.

- DO NOT:
- Do not use any abrasive cleansers, cloths, or paper towels.
 - Do not use any cleaning agents containing acids, polish abrasives, or harsh cleaners or soaps.

* Regular and routine cleaning will reduce the need for heavy cleaning and polishing. If heavy cleaning is required, the following procedures are recommended:

- DO:
1. Remove as much surface dirt and film using a damp cloth.
 2. Use any of the following to remove tough surface film and build-up:
 - Mild liquid detergents
 - Clear liquid glass cleaners
 - Non-acidic, non-abrasive gentle liquid or fully dissolved powder cleansers mixed according to manufacturers directions
 - Non-abrasive liquid polishers
 3. Once clean, thoroughly wipe product again with damp cloth to remove cleaner or polish and dry with soft cotton cloth.

If you have any doubts or questions concerning care and maintenance of your product, please contact your local American Standard representative.

Warranty:

Subject to local warranty terms.

Visit americanstandard-apac.com or contact your local American Standard representative for specific warranty information.



Attention:
Please leave the manual
with the user after installation.

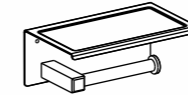

FFAS0498-908XXXBF0
FFAS0498-908XXXBT0
Concept Square Single Tissue
Holder w/ Shelf
(XXX=AL0/A00/DA0/GL0/440)

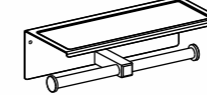

FFAS0499-908XXXBF0
FFAS0499-908XXXBT0
Concept Square Double Tissue
Holders w/ Shelf
(XXX=AL0/A00/DA0/GL0/440)



FFAS1498-908XXXBF0
FFAS1498-908XXXBT0
Concept Round Single Tissue
Holder w/ Shelf
(XXX=AL0/A00/DA0/GL0/440)

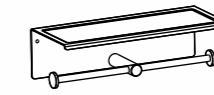

FFAS1499-908XXXBF0
FFAS1499-908XXXBT0
Concept Round Double Tissue
Holders w/ Shelf
(XXX=AL0/A00/DA0/GL0/440)

American Standard

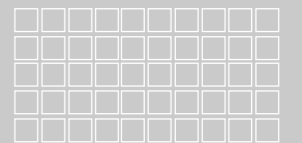

Installation/Operating
Manual

Thank you for selecting American Standard, the benchmark of fine quality for over 100 years.

To ensure that your installation proceeds smoothly, please read these instructions carefully before you begin.

* American Standard continually improves our product design and performance. American Standard reserves the right to modify the dimensions and specifications of our product accordingly without any prior notification.

* Actual dimensions and specifications may vary, refer to physical product for exact dimensions and specifications.

Pre-Installation Checks

* All instruction procedures must comply in strict accordance with applicable local plumbing and building codes.

* Before assembling, please make sure the drilled position in the assembling part is safe.

* Check installation distances in the dimension diagram to ensure correct installation.

Recommended Tools and Materials



Tape Measure



Hammer



Screwdriver



Drill

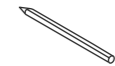

Pencil

Dimensions

Unit: mm

FFAS0498-908XXXBF0
FFAS0498-908XXXBT0

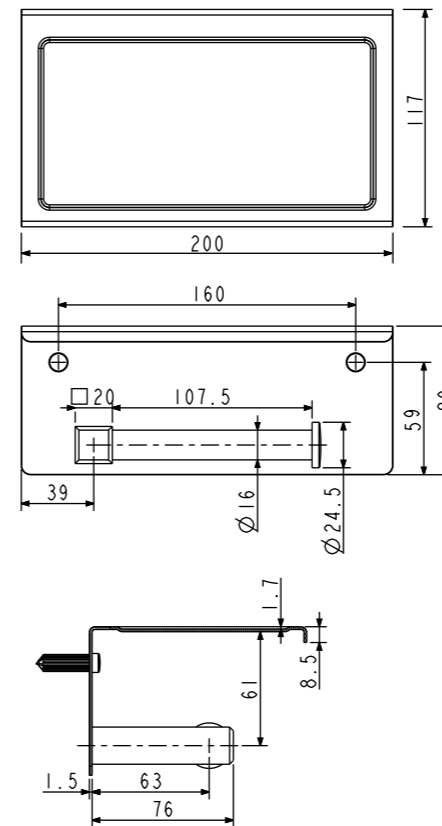

FFAS0499-908XXXBF0
FFAS0499-908XXXBT0

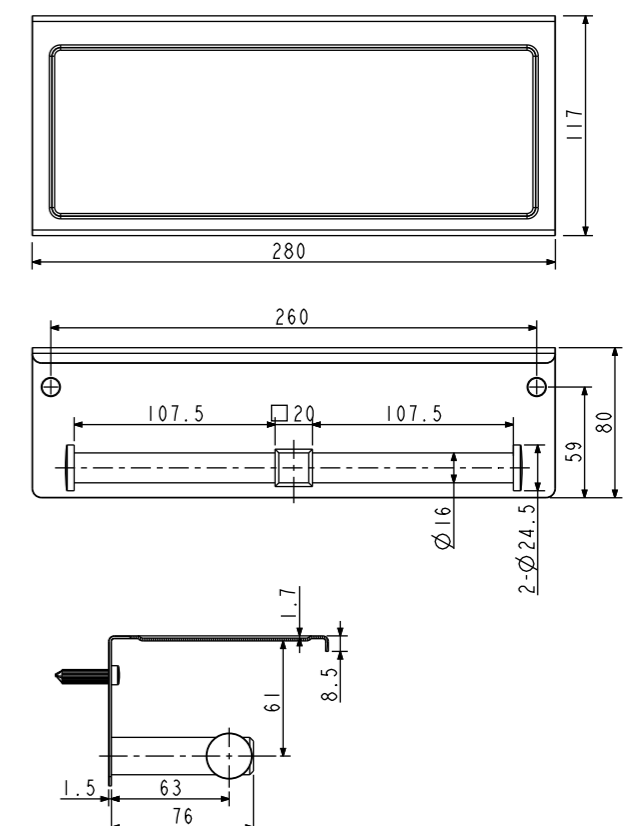

Dimensions

Unit: mm

FFAS1498-908XXXBF0
FFAS1498-908XXXBT0

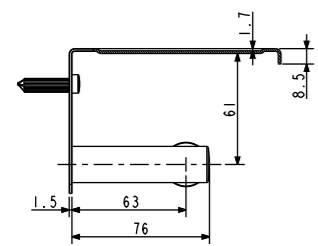
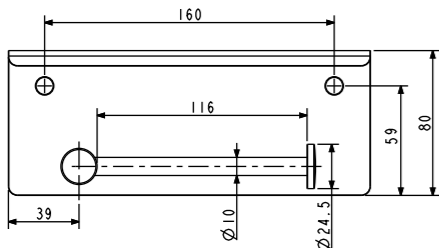
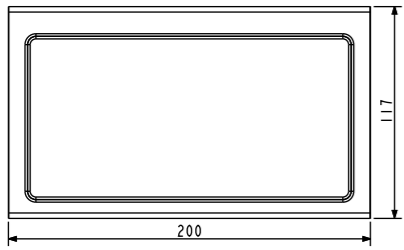

FFAS1499-908XXXBF0
FFAS1499-908XXXBT0

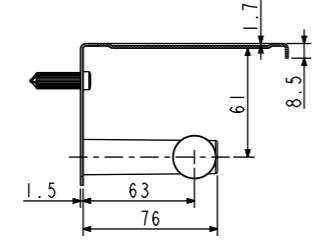
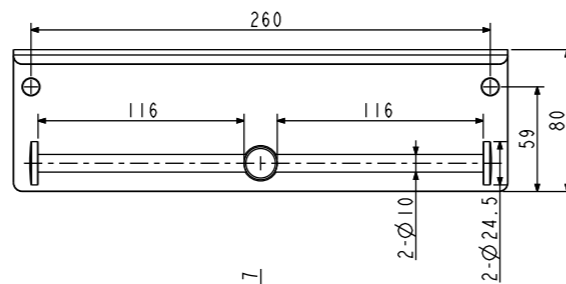
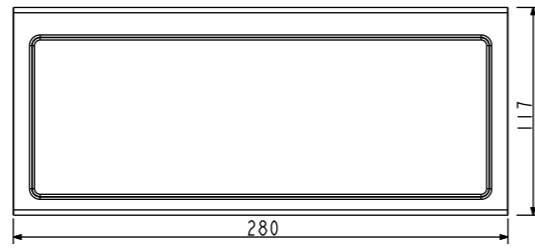

Parts List

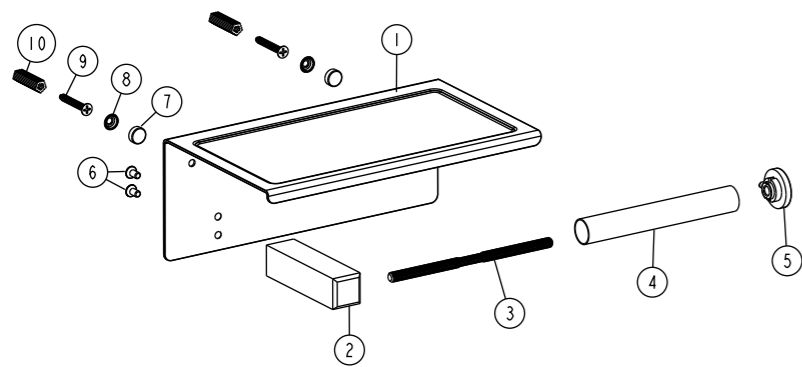

FFAS0498-908XXXBF0
FFAS0498-908XXXBT0

No.	Parts Name	Q'ty
1	Body	1
2	Supporting rod	1
3	Bolt	1
4	Bar	1
5	Buckle	1
6	Screw	2
7	Cap	2
8	Mounting base	2
9	Screw	2
10	Expansion anchor	2

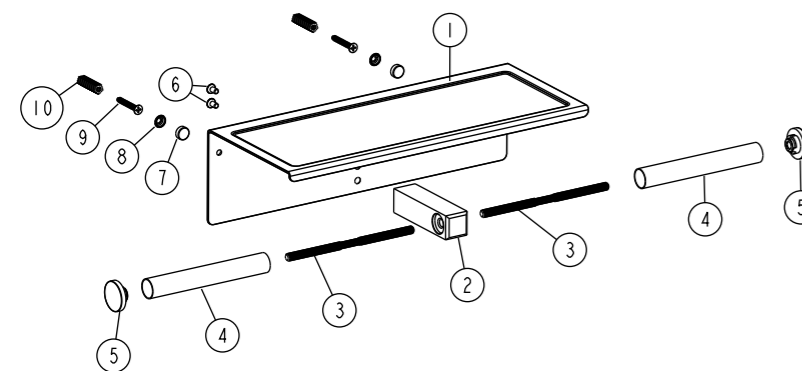

FFAS0499-908XXXBF0
FFAS0499-908XXXBT0

No.	Parts Name	Q'ty
1	Body	1
2	Supporting rod	1
3	Bolt	2
4	Bar	2
5	Buckle	2
6	Screw	2
7	Cap	2
8	Mounting base	2
9	Screw	2
10	Expansion anchor	2

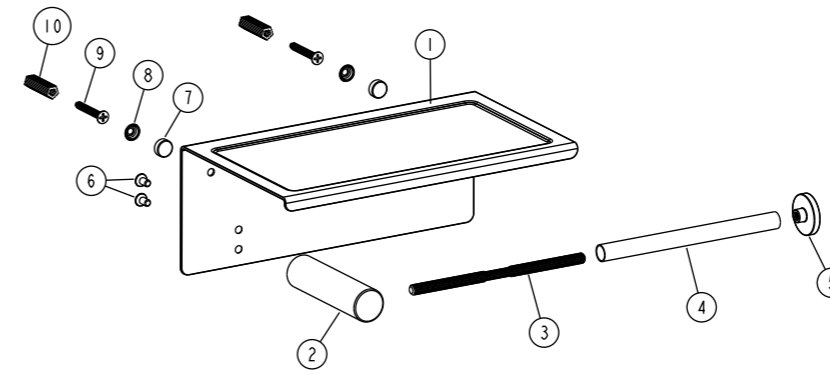

FFAS1498-908XXXBF0
FFAS1498-908XXXBT0

No.	Parts Name	Q'ty
1	Body	1
2	Supporting rod	1
3	Bolt	1
4	Bar	1
5	Buckle	1
6	Screw	2
7	Cap	2
8	Mounting base	2
9	Screw	2
10	Expansion anchor	2

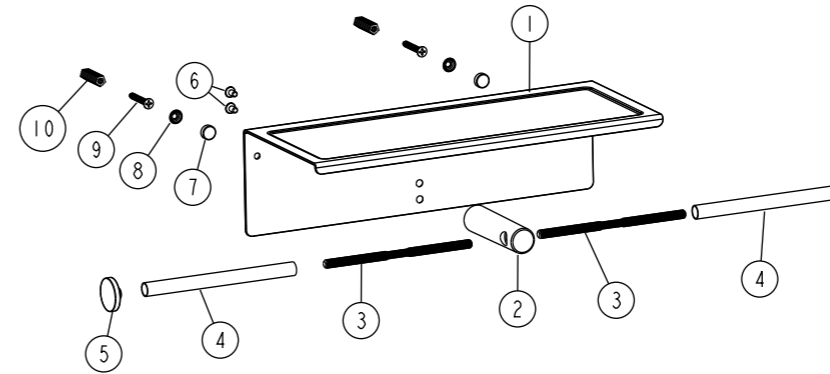

FFAS1499-908XXXBF0
FFAS1499-908XXXBT0

No.	Parts Name	Q'ty
1	Body	1
2	Supporting rod	1
3	Bolt	2
4	Bar	2
5	Buckle	2
6	Screw	2
7	Cap	2
8	Mounting base	2
9	Screw	2
10	Expansion anchor	2

Installation

