

Milano

Extended Basin Mixer with Pop-up
Drain

FFAS0902-102500BF0



FEATURES

- Water Saving
- Comfort Move
- Durashine

SPECIFICATIONS

- 35mm Ceramic Disc Cartridge, Life Cycle: 500,000 cycle;
- Zinc Die Casting Handle, Chrome Finish;
- Cast Brass Body, Chrome Finish;
- W/ Neoperl M24X1 Aerator, Flow Rate is less than 6L/min at 1bar;
- W/ 600mm Flexible Hose;
- W/ Press Action Pop-up Drain;
- Surface Treatment: Ni \geq 6.0u, Cr \geq 0.2u;
- Water Pressure: 0.5bar ~ 7.5bar;
- Recommended Water Pressure: 1bar ~ 5bar;

FINISHES AVAILABILITY

- Chrome (- CP)

SHIPPING WEIGHT

- Gross Weight: 2.93 KG

STANDARDS CRITERIA

- GB 18145-2014

American Standard

DIMENSIONAL DRAWING

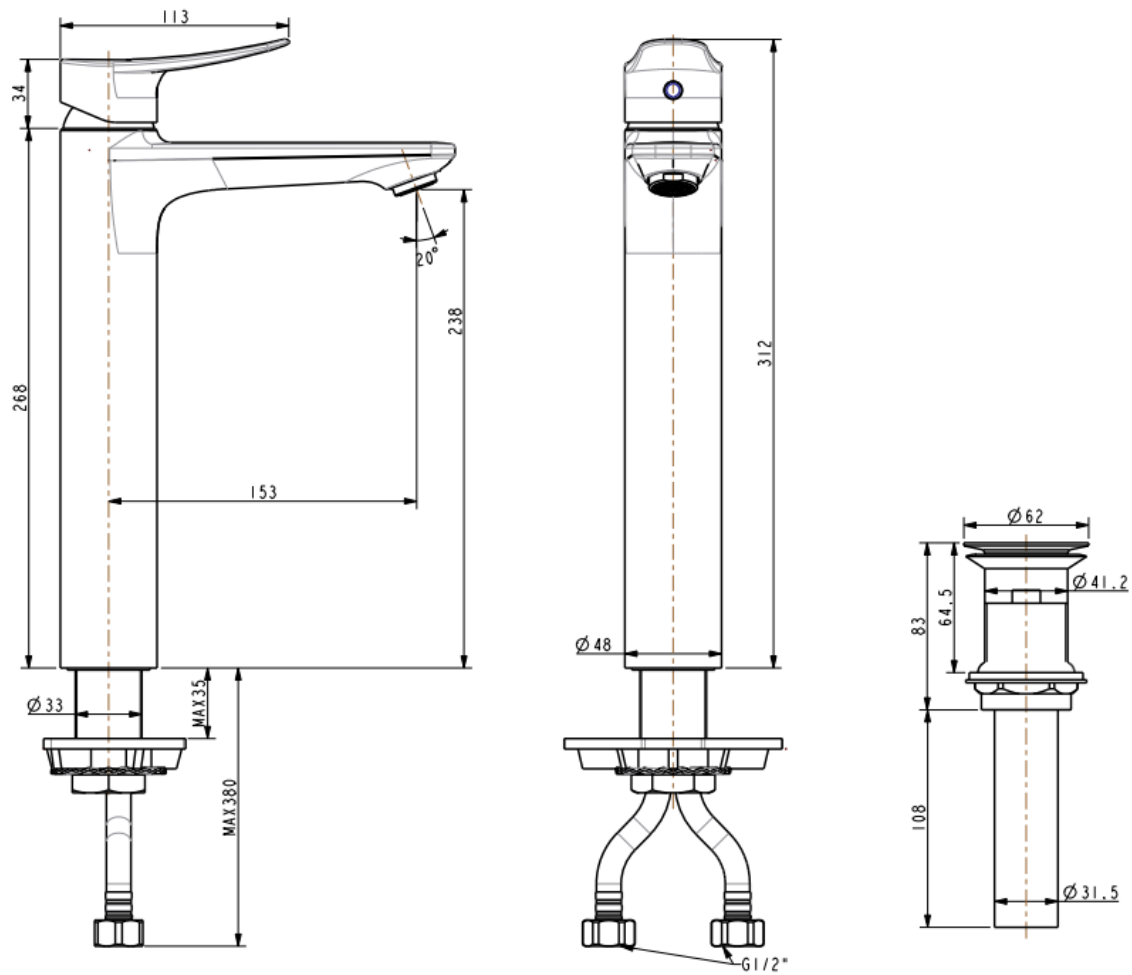

This document is the property of American Standard. It can neither be reproduced, nor communicated, without authorization.

American Standard reserves the right to change dimensions and specifications without notice; we assume no liability for the use of obsolete dimensions.