

Acacia Evolution

Exposed Shower Mixer
With Shower Kit
FFAS1312-701500BF0



FEATURES

- Modern design that can fit with any style of bathroom
- Ceramic disc valve for a life time use
- Strong brass construction
- Nickel and chromium plating for durable finish
- Chrome cover on top for space utilization
- With 5-function Hand Shower Set
 - 1) Spray;
 - 2) Massage;
 - 3) Champagne;
 - 4) Spray+Massage;
 - 5) Spray+Champagne;
- With 1.5m twist-free shower hose and adjustable shower hanger
- Flow Rate @ 0.1 MPa (With Shower): 5.76 L/Min

SPECIFICATIONS

- Exposed Shower Mixer Faucet
- Wall-Mount Installation

FINISHES AVAILABILITY

- Chrome (- CP)

SHIPPING WEIGHT

- Net Weight: 3.75 KG
- Gross Weight: 4 KG

STANDARDS CRITERIA

- TIS 2066-2552
- GB 18145-2014

DIMENSIONAL DRAWING

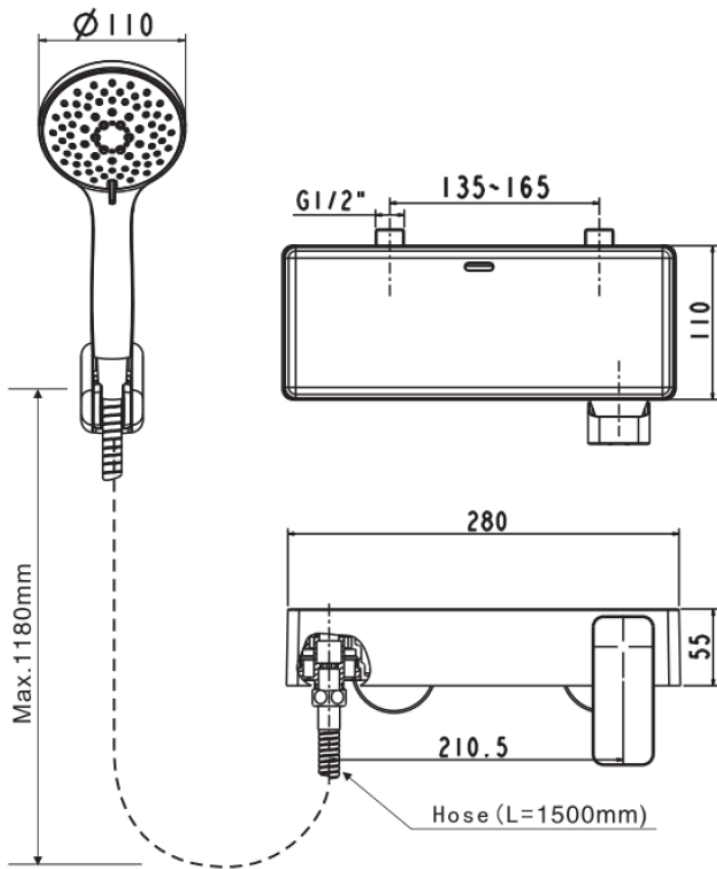

This document is the property of American Standard. It can neither be reproduced, nor communicated, without authorization.

American Standard reserves the right to change dimensions and specifications without notice; we assume no liability for the use of obsolete dimensions.