

Tolerance, Unless Otherwise Stated, Is			
Above 0.5 to and including 6	±0.1		
Excess 6 to and including 30	±0.2		
Excess 30 to and including 120	±0.3		
Excess 120 to and including 315	±0.5		
Excess 315 to and including 1000	±0.8		
Excess 1000 to and including 2000	±1.2		

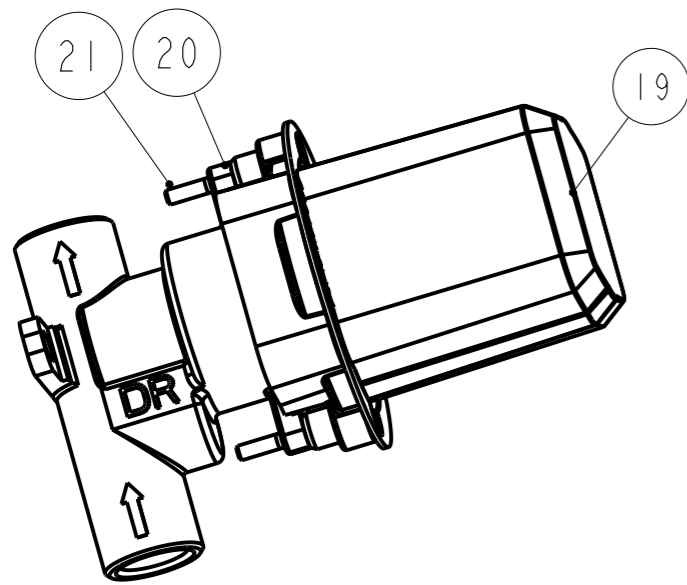
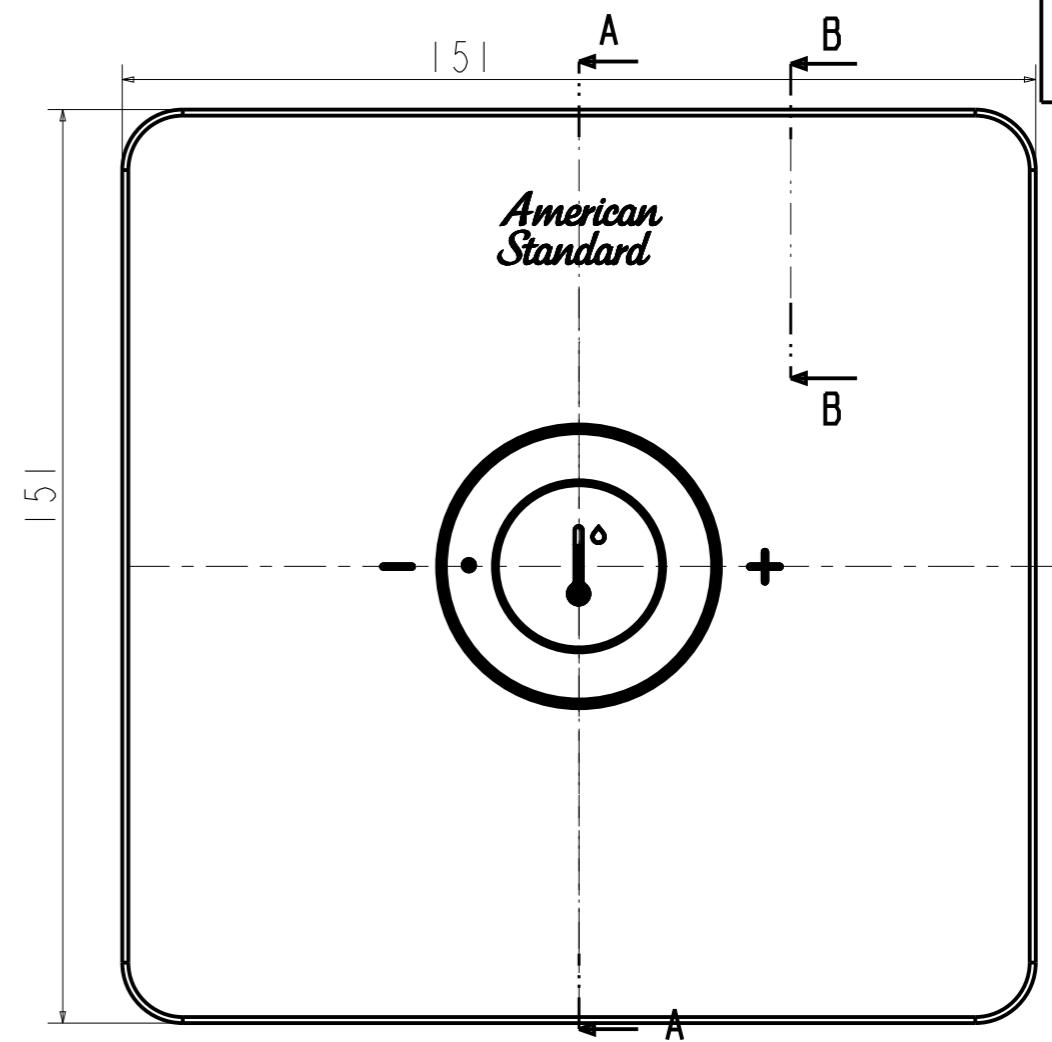
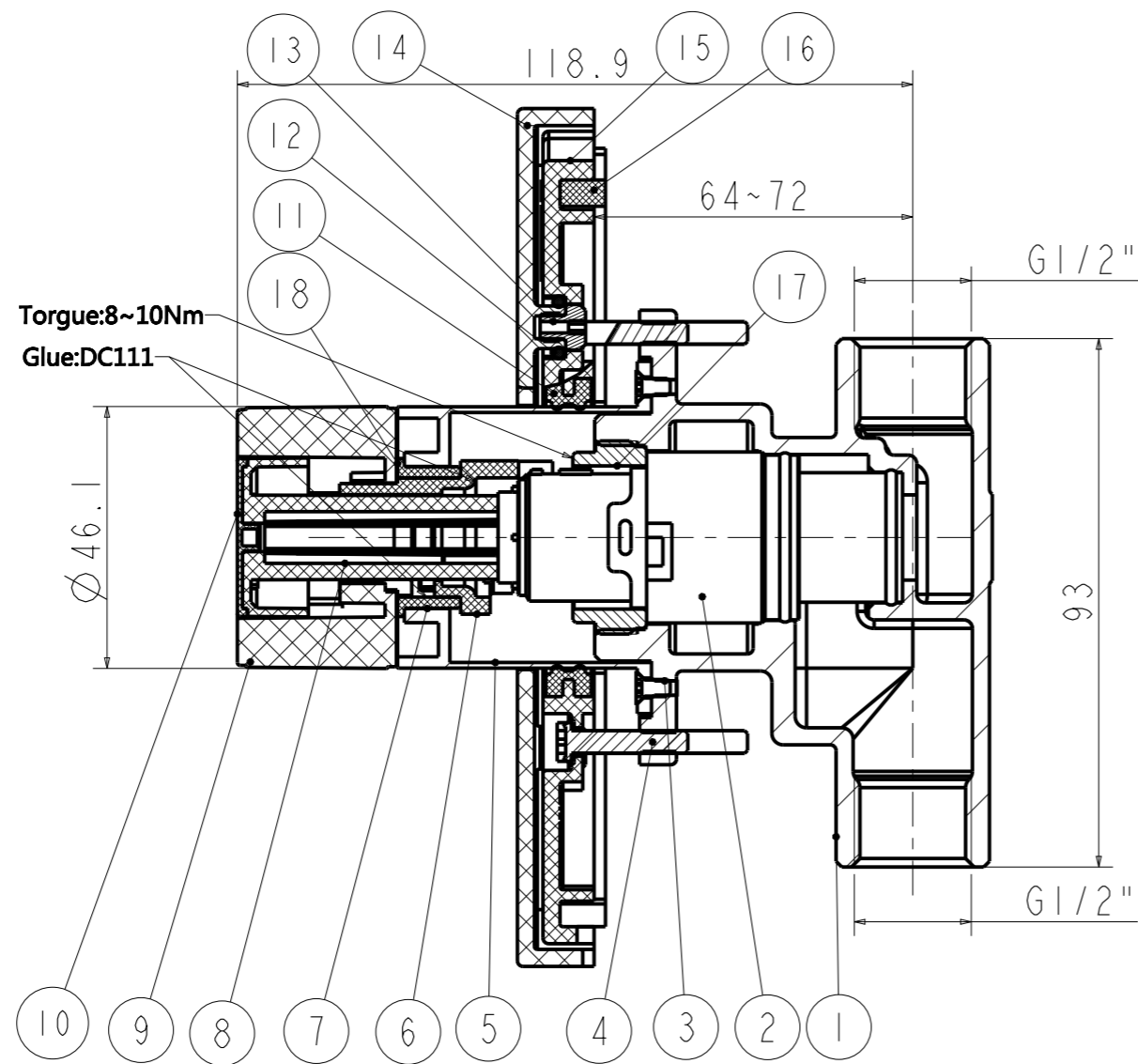

NO.	Part NO.	Description	Material	QTY	Surface Treatment
21	FF1-CN521N00000268	Screw (M4X20)	SUS304	2	
20	FF1-CN521J00000338	Bushing	POM	2	
19	FF1-CN521Z00000212	Project cover	PP	1	
18	FF1-CN521G0003799P	Washer (26*21*0.2)	TEFLON	1	
17	FF1-CN521N00002299	Cartridge Lock Nut	Hpb59-1	1	
16	FF1-CN521K00000034	Washer	EVA	1	
15	FF1-CN521F00000014	Fixing Plate	ABS	1	
14	FF1-CN521F0004350P	Escutcheon	ABS	1	Cu>15.0u, Ni>7.0u, Cr>0.25u
13	FF1-CN521J00000214	Screw	Hpb59-1	4	Ni>5.0u, Cr>0.2u
12	FF1-CN521G00000291	O-Ring(7X2)	EPDM	4	
11	FF1-CN521G00000206	Sealing	NBR	1	
10	FF1-CN521F0004850P	Cover for Pre-warming	ABS	1	Cu>15.0u, Ni>7.0u, Cr>0.25u
9	FF1-CN521L0004150P	Handle	ABS	1	Cu>15.0u, Ni>7.0u, Cr>0.25u
8	FF1-CN521J0010409P	Push Button	POM	1	
7	FF1-CN521J0010599P	Adpater	POM	1	
6	FF1-CN521J0010699P	Handle Connector	POM	1	
5	FF1-CN521J0010850B	Cartridge Bushing	HPb59-1	1	Ni>5.0u, Cr>0.2u
4	FF1-CN521N00000185	Screw (M4X20)	SUS304	2	
3	FF1-CN521N00000269	Screw	SUS304	2	
2	FF1-CN521C00000499	Cartridge	Assembly	1	
1	FFZZ0021-0010599MC	Body	BSC3(DZR)	1	

DESIGNED	CHECKED	APPROVED	SCALE	MATERIAL	WEIGHT	DWG NO.	TITLE
			4:5	Assembly		FFAS0928-799500BC0	EasySET Control Valve for Pre-warming

REV	DESCRIPTION	DATE	NAME

**American Standard**