

Tolerance, Unless Otherwise Stated. Is			
Above	0.5 to and including	6	±0.1
Excess	6 to and including	30	±0.2
Excess	30 to and including	120	±0.3
Excess	120 to and including	315	±0.5
Excess	315 to and including	1000	±0.8
Excess	1000 to and including	2000	±1.2

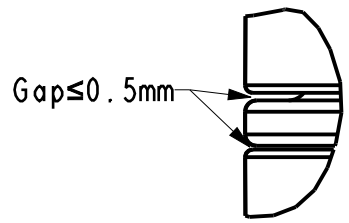

Gap ≤ 0.5mm

DETAIL F
SCALE 5.000

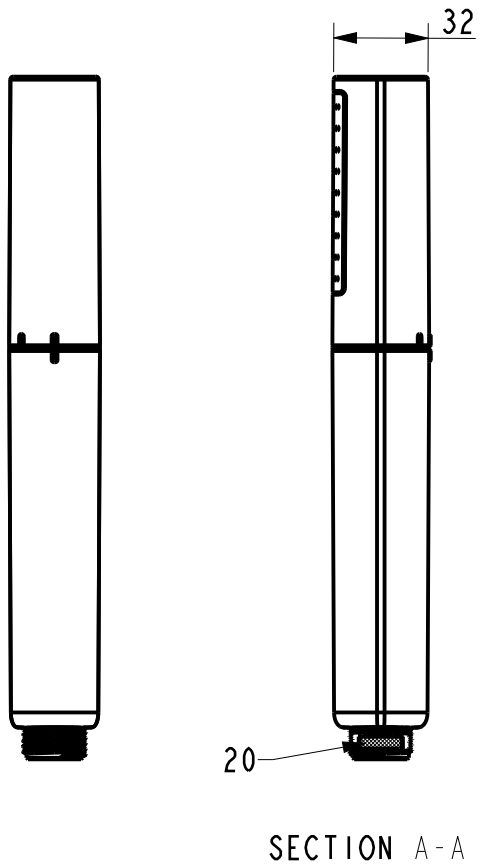

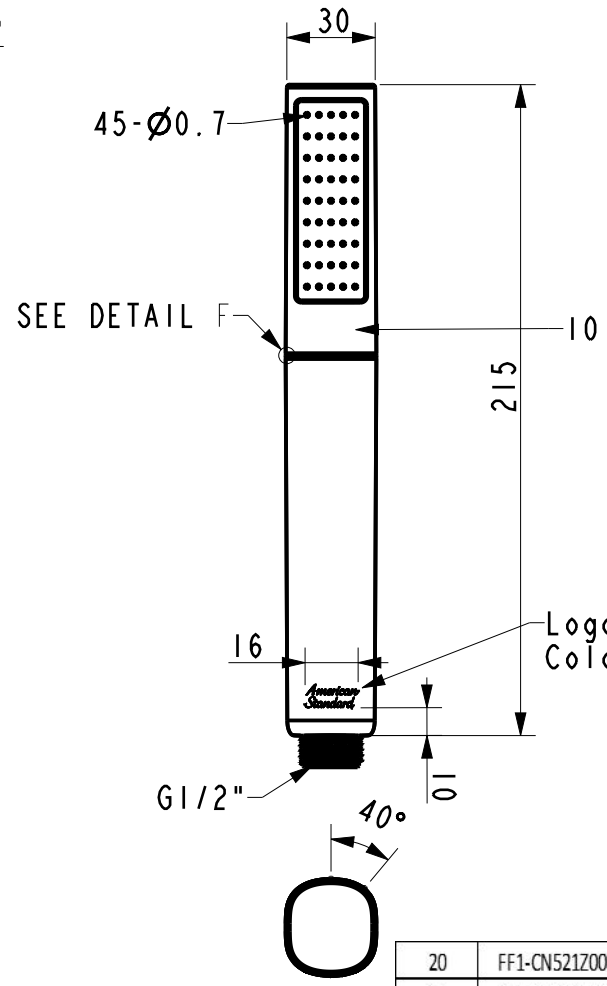

SECTION A-A



Logo: Silk printing
Color: Pantone cool gray 11c

- 技术要求:
- 花洒为单功能花洒, 顶盖可拆卸功能;
 - 花洒主体材质为ABS757, 表面镀铬, 面罩为黑色, 色号: Supermatt black (KWO);
 - 花洒的相关性能符合《WI10.0406内控标准-花洒》相关要求;
 - 花洒包装为普通包装;
 - 美标Logo江门厂镭射+丝印;
 - 1Bar 下的流量为4.2~8L/min.
 - 带“”为重要尺寸, 螺纹要求通规通, 止规止。

20	FF1-CN521Z0008299P	2.5GPM恒流阀 (Neoperl 58.6158.0)	Assembly	1	
10	FF1-CN521H0007350P	双功能杆形花洒 (哑黑)	Assembly	1	
No.	Part No.	Part name	Material	QTY	Remark

DESIGNED	刘卫群	2021.10.19	TITLE		
CHECKED		2021.10.19	REF		
APPROVED		2021.10.19	双功能杆形花洒 (哑黑) (带2.5GPM恒流阀)		
SCALE	MATERIAL	WEIGHT	DWG NO.		
2:5	Assembly		FFASS507-000440BF0		

REV	DESCRIPTION	DATE	NAME